



**Parts Manual
E17/E20 Floor Scrubber
Brush Drive**

Technical Specifications

Model E17/E20

Model No. E17BD / E17BDCE / E17BDQP / E17BDQPCE
 E17BDQPG / E17BDQPGCE
 E20BD / E20BDCE / E20BDQP / E20BDQPCE
 E20BDQPG / E20BDQPGCE

	E17	E20
Current (Max)	32 amps	32 amps
Battery Capacity (Lead Acid)	105Ah @20 hr	105Ah @20 hr
Battery Capacity (Gel)	95Ah @20 hr	95Ah @20 hr
Sound Level	69 dBA	69 dBA
Cleaning path width	17 in (43 cm)	20 in (51 cm)
Squeegee width	33 in (84 cm)	33 in (84 cm)
Theoretical productivity (Brush Drive)	12,750 ft ² /hr (1,185 m ²)	15,000 ft ² /hr (1,394 m ²)
Working speed (Brush Drive)	1.7 mph (2.7 km per hr)	1.7 mph (2.7 km per hr)
Transport speed	3 mph (4.8 km per hr)	3 mph (4.8 km per hr)
Rated voltage	24 volts	24 volts
Vacuum flow	65 cfm (110 m ³ /hr)	65 cfm (110 m ³ /hr)
Vacuum waterlift	45 inches (112mbar)	45 inches (112mbar)
Vacuum power	.60 HP (450 W)	.60 HP (450 W)
Brush type	Disc	Disc
Brush motor(s) power	3/4 HP (560W)	3/4 HP (560W)
Number of brushes	1	1
Brush RPM	180 RPM	180 RPM
Aqua-Stop equipped	Coming Soon	Coming Soon
Solution capacity	12Gal (45 liters)	12 Gal (45 liters)
Recovery capacity	13 Gal (49 liters)	13 Gal (49 liters)
Working Grade	2%	2%
Weight with batteries	306 lbs (139 kg)	313 lbs (142 kg)
Weight without batteries	196 lbs (89 kg)	203lbs (92 kg)
Dimensions (LxWxH)	44.4 x 18.8 x 42.3 (112.8 x 47.8 x 107.4 cm)	47.4 x 21.3 x 42.3 (120.4 x 54.1 107.4 cm)

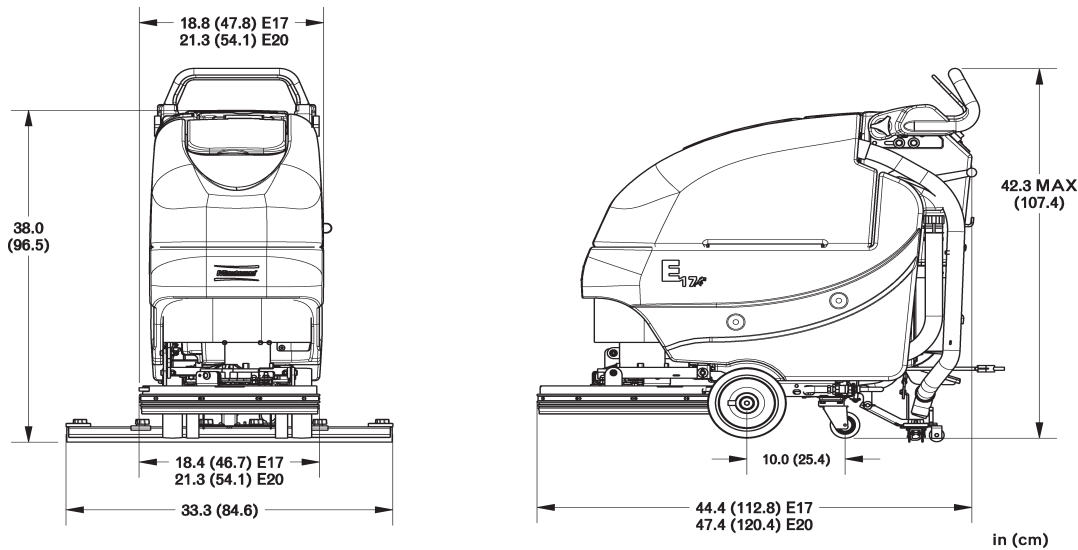

For Safety When Servicing or Maintaining Machine

- Stop on level surface.
- Disconnect the power to the machine by pulling the red Battery Connector located under the recovery tank near the batteries.
- Avoid moving parts. Do not wear loose jackets, shirts, or sleeves when working on machine.
- Avoid contact with battery acid. Battery acid can cause burns. When working on or around batteries, wear protective clothing and safety glasses. Remove metal jewelry. Do not lay tools or metal objects on top of batteries.
- Do not clean machine with a pressure washer.
- Authorized personnel must perform repairs and maintenance. Use Minuteman supplied replacement parts.



DECLARATION OF CONFORMITY

MANUFACTURER'S NAME: Minuteman International Inc.

MANUFACTURER'S ADDRESS: 111 South Rohlwing Road
Addison, IL. 60101

EQUIPMENT DESCRIPTION: E17/ E20 Walk-Behind Scrubber

EQUIPMENT MODEL DESIGNATION: E17BDQPCE, E17BDQPGCE,
E17BDCE, E20BDCE, E20BDQPCE,
E20BDQPGCE

Application of Council Directives: 98/37/EC, 89/336/EEC

Harmonized standards complied with: EN 60335-2-72, EN 60335-1,
EN 61000-6-2, EN 61000-6-3

I, the undersigned, hereby declare that the equipment specified above conforms to the above Directive(s) and Standard(s).

SIGNATURE:

DATE:

9.11.2007

**PRINTED NAME:
TITLE:**

**Ruediger Schroeder
Exec. VP and COO**

Form: ECO 200 *

Table of Contents

E17 Main Assembly	1
E17 Main Assembly BOM	2
E20 Main Assembly	3
E20 Main Assembly BOM	4
Brush Drive Base Assembly	5
Brush Drive Base Assembly BOM	6
E17/20 Base Assembly	7
Chassis Assembly	8
Chassis Assembly BOM	9
Solution Valve Assembly	10
Solution Tank Assembly	11
Lift Pedal Stop Assembly	12
Recovery Tank Assembly	13
Recovery Tank Assembly BOM	14
Handle Assembly	15
Battery Tray Assembly	16
Electrical Box Assembly	17
Electrical Box Assembly BOM	18
Electrical Box Cover Assembly	19
Vac Motor Assembly	20
17" Brush Deck Assembly	21
17" Brush Deck Assembly BOM	22
20" Brush Deck Assembly	23
20" Brush Deck Assembly BOM	24
E17/20 Brush Hub Assembly	25
E17 Rear Squeegee Assembly	26
E20 Rear Squeegee Assembly	27
E17 Squeegee Mechanism Assembly	28
E20 Squeegee Mechanism Assembly	29
Wiring Diagrams	30

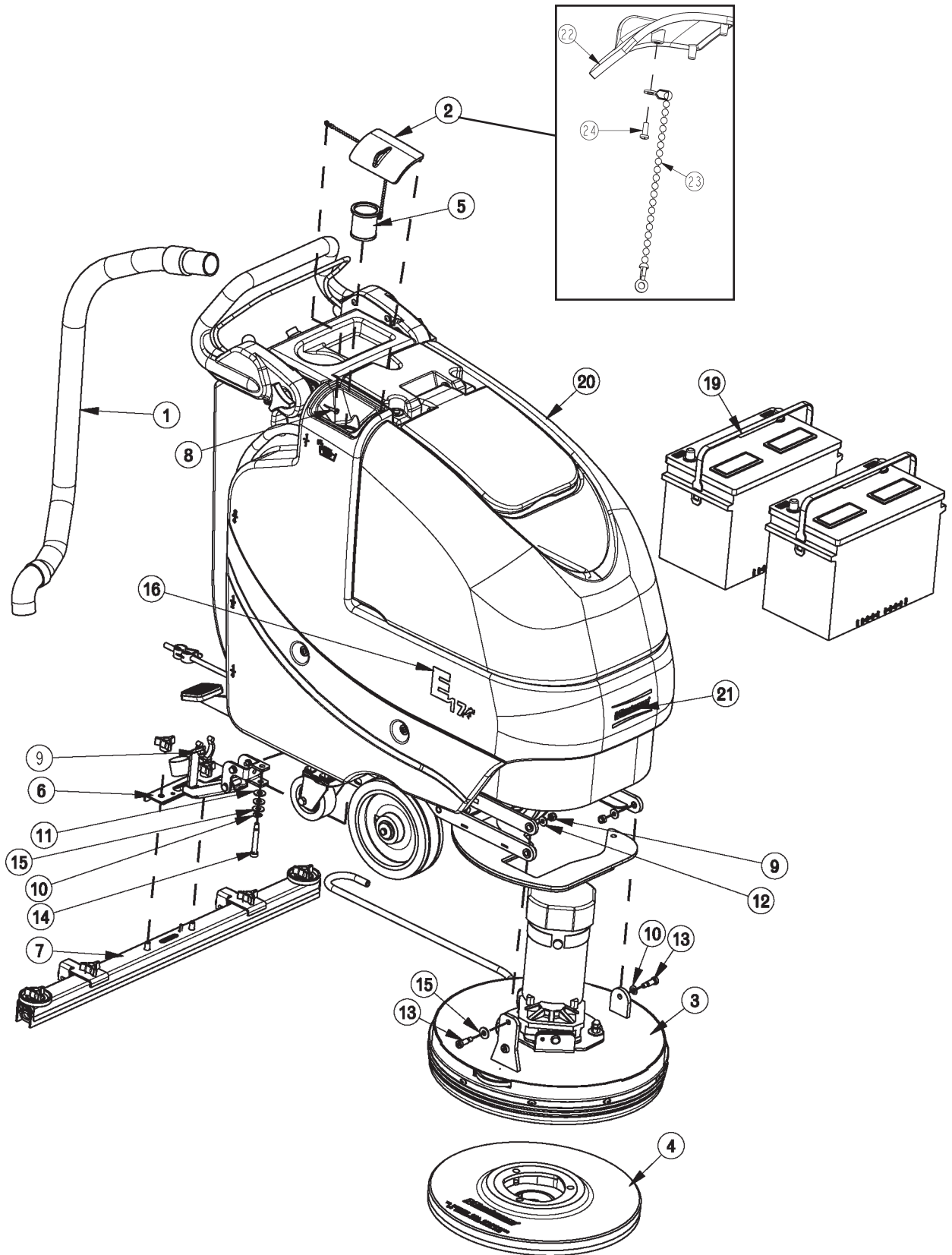

BILL OF MATERIAL			
ITEM	PART NO.	REQ'D	DESCRIPTION
1	172010	1	HOSE, CLEAR VAC W/ 45 CUFF
2	172018	1	SOLUTION TANK LID ASSY
3	172090	1	BRUSH DECK ASSY 17"
4	172117-2	1	17" PAD DRIVER
5	172159	1	FILTER, FILL PORT, ES1720
6	172170	1	BD SQUEEGEE LIFT MECH ASSY
7	210080	1	SQUEEGEE ASY COMP 20" STR
8	711118	1	SCR-ST-A 10 X .75 SS
9	711374	4	NUT-NYLOC 5/16-18
10	711523	3	WSR-WAVE .37X .68 X .08
11	711569	1	WSR-FLT .390 X .880 X .062 NYL
12	711575	3	WSR-FLT .31x.75x..06ST
13	712081	3	SHOULDER BLT 5/16-18 X 3/8 X .75
14	712143	1	BLT-SHLD 3/8 X 2.0, 5/16-18
15	712301	3	WSR-FLAT .37 X .87 X .06
16	715917	2	DECAL, E17
17	740164-1	1	JUMPER CABLE ASSY, RED 4G 12"
18	747649	1	CABLE ASSY, BATTERY E17
19	956712	2	BATTERY, 12V 105 AH
19G	956100	2	GEL BATTERY 12V 100AH
20	172001BD-120	1	E17 BRUSH DRV BASE ASSY-120V CHARGER
20CE	172001BD-230	1	BRUSH DRV BASE ASSY-230V CHARGER
21	715914W	1	DECAL, MINUTEMAN W/SWOOSHES, WHITE
22	172008	1	SOLUTION TANK LID
23	172123	1	CHAIN, BEADED SS W/ EYELETS
24	712145	1	SCR-MC 6-32 X .37 PPH SS

OPTIONAL BRUSHES		
ITEM	PART NO.	DESCRIPTION
4.1	172117-1	BRUSH, 17" NYLON
4.2	172117-3	BRUSH, 17" NYLO GRIT
4.3	172117-4	BRUSH, 17" STRATA GRIT
4.4	172117-5	BRUSH, 17" DYNA-SCRUB 500GR
4.5	172117-6	BRUSH, 17" SCRUB-GRIT2 120GR

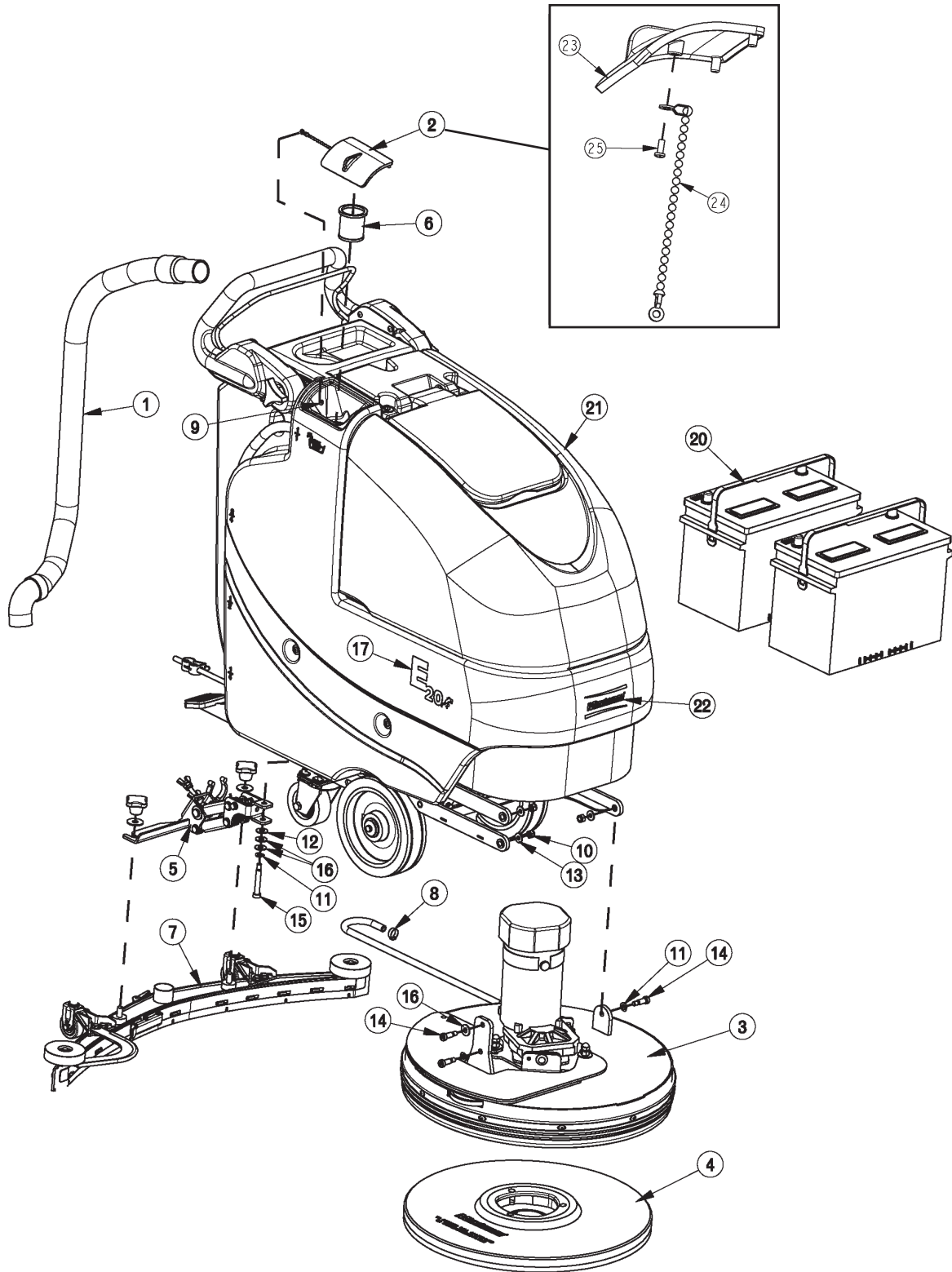

BILL OF MATERIAL			
ITEM	PART NO.	REQ'D	DESCRIPTION
1	172010	1	HOSE, CLEAR VAC W/ 45 CUFF
2	172018	1	SOLUTION TANK LID ASSY
3	172100	1	BRUSH DECK ASSY 20"
4	172120-2	1	20" PAD DRIVER
5	172150	1	SQUEEGEE LIFT MECH ASSY
6	172159	1	FILTER, FILL PORT, ES1720
7	172270	1	SQUEEGEE, 34" (860)
8	450076	1	CLAMP-CRIMP 185R SS
9	711118	1	SCR-ST-A 10 X .75 SS
10	711374	3	NUT-NYLOC 5/16-18
11	711523	3	WSR-WAVE .37X .68 X .08
12	711569	1	WSR-FLT .390 X .880 X .062 NYL
13	711575	3	WSR-FLT .31x.75x.06ST
14	712081	3	SHOULDER BLT 5/16-18 X 3/8 X .75
15	712143	1	BLT-SHLD 3/8 X 2.0, 5/16-18
16	712301	3	WSR-FLAT .37 X .87 X .06
17	715920	2	DECAL, E20
18	740164-1	1	JUMPER CABLE ASSY, RED 4G 12"
19	747649	1	CABLE ASSY, BATTERY E17
20	956712	2	BATTERY, 12V 115AH
20G	956100	2	GEL BATTERY 12V 100AH
21	172001BD-121	1	E20 BRUSH DRV MAIN ASSY-120V CHARGER
21CE	172001BD-231	1	E20BRUSH DRV BASE ASSY-230V CHARGER
22	715914W	1	DECAL, MINUTEMAN W/SWOOSHES, WHITE
23	172008	1	SOLUTION TANK LID
24	172123	1	CHAIN, BEADED SS W/ EYELETS
25	712145	1	SCR-MC 6-32 X .37 PPH SS

OPTIONAL BRUSHES		
ITEM	PART NO.	DESCRIPTION
4.1	172120-1	BRUSH, 20" NYLON
4.2	172120-3	BRUSH, 20" POLY GRIT
4.3	172120-4	BRUSH, 20" STRATA GRIT
4.4	172120-5	BRUSH, 20" DYNA-SCRUB 500GR
4.5	172120-6	BRUSH, 20" SCRUB-GRIT2 120GR

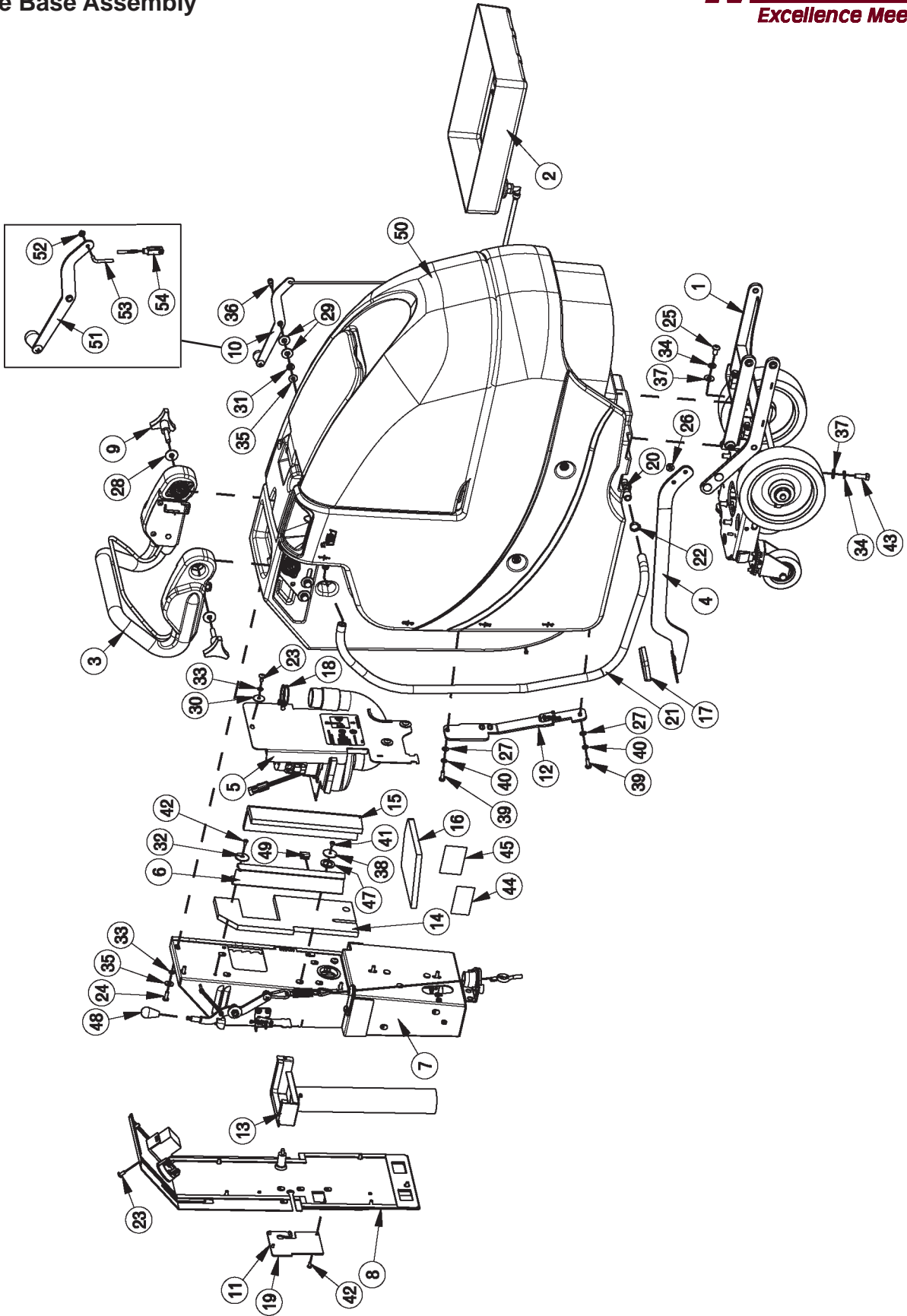

BILL OF MATERIAL - 172001BD-120/230/121/231							
ITEM	PART NO.	REQ'D	DESCRIPTION	ITEM	PART NO.	REQ'D	DESCRIPTION
1	172002	1	E17 BD CHASSIS ASSY	28	711507	2	WSR-FLAT .37 X 1.12 X .06
1A	172002-1	1	E20 BD CHASSIS ASSY	29	711508	2	WSR-FLAT .44X 1.0X.08
2	172012	1	BATTERY TRAY ASSY	30	711519	3	WSR- FLAT .25 X 1.01 X .06
3	172016	1	E1720 BD HANDLE ASSY	31	711523	1	WSR-WAVE .37X .68 X .08
4	172032	1	LIFT PEDAL WMT	32	711543	1	WSR-HELICAL #10
5	172050	1	VAC MOTOR ASSY	33	711544	9	WSR-HELICAL 1/4
6	172055	1	BKT, VAC AREA INSIDE COVER	34	711546	6	WSR-HELICAL 3/8
7	172070-120	1	ELEC BOX BD ASSY 120V	35	711575	6	WSR-FLT .31x.75x.06ST
8	172073	1	BD ELEC BOX COVER ASSY	36	712041	1	BLT- SHLDR 1/4-20 X .44 X .37
9	172085	2	KNOB, 3/8-16 STUD, 3 LOBE	37	712301	6	WSR-FLAT .37 X .87 X .06
10	172112	1	SOL CONTROL ASSY	38	712312	2	WSR-FLAT .187 X 1.25
11	172129	1	BKT, PWR CORD MOUNT	39	712562	2	BOLT-HH 1/4-20X3/4 SS
12	172157	1	LIFT PEDAL STOP ASSY	40	712758	2	WSR-HELICAL 1/4 SS
13	172179	1	CHARGER INLET ASSEMBLY	41	712800	1	SCR-MC 10-24 X .25 ST PL
14	172184	1	FOAM COVER, REAR 1	42	712810	5	SCR-MC 10-24 X .37 ST PL
15	172185	1	FOAM COVER, REAR 2	43	713042	4	BLT-HH 3/8-16 X 1 #5
16	172187	1	FOAM COVER, FRONT 2	44	715029	1	DECAL-NAME PLATE SERIAL
17	210142	1	PEDAL PAD	45	715047	1	DECAL-CLEAR LAMINATE 2X3
18	260203	1	WIRE GRIP HOSE CLAMP	46	715950	1	LABEL, PATENT NUMBERS
19	293080	1	STRAIN RELIEF-HEYCO 1207	47	717025	1	WSR-FLAT 13/16ID X 1.25 X .08
20	342440	1	FITTING, TEE 3/4MPT 1/2BARB PP	48	760592	1	KNOB, OVAL TAPERED
21	430156	1	HOSE, 1/2 X 42 CLEAR	49	809443	1	CLIP-WIRE & CORD
22	450093	2	CRIMP CLAMP 3/4" STEPLESS	50	172001BASE	1	ES1720 BASE ASSY
23	710178	10	SCR-MC 1/4-20 X .50 TRUSS STPL	51	172115	1	SOL CNTRL LEVER ASSY
24	710380	5	SCR-MC RD HD 1/4-20 X .75 STL PL	52	172122	1	NUT, PUSH-ON WSR CAP, 3/16
25	710985	2	SCR-SC 3/8-16 X .62 ST PL	53	172069	1	ROD, SOL. CTRL, ES1720
26	711379	2	NUT, FLANGED WIZZ 5/16-18	54	172062	1	YOKE, 3/16 CLEVIS, 10-32, LONG
27	711504	2	WSR-FLAT 1/4 ID SS				

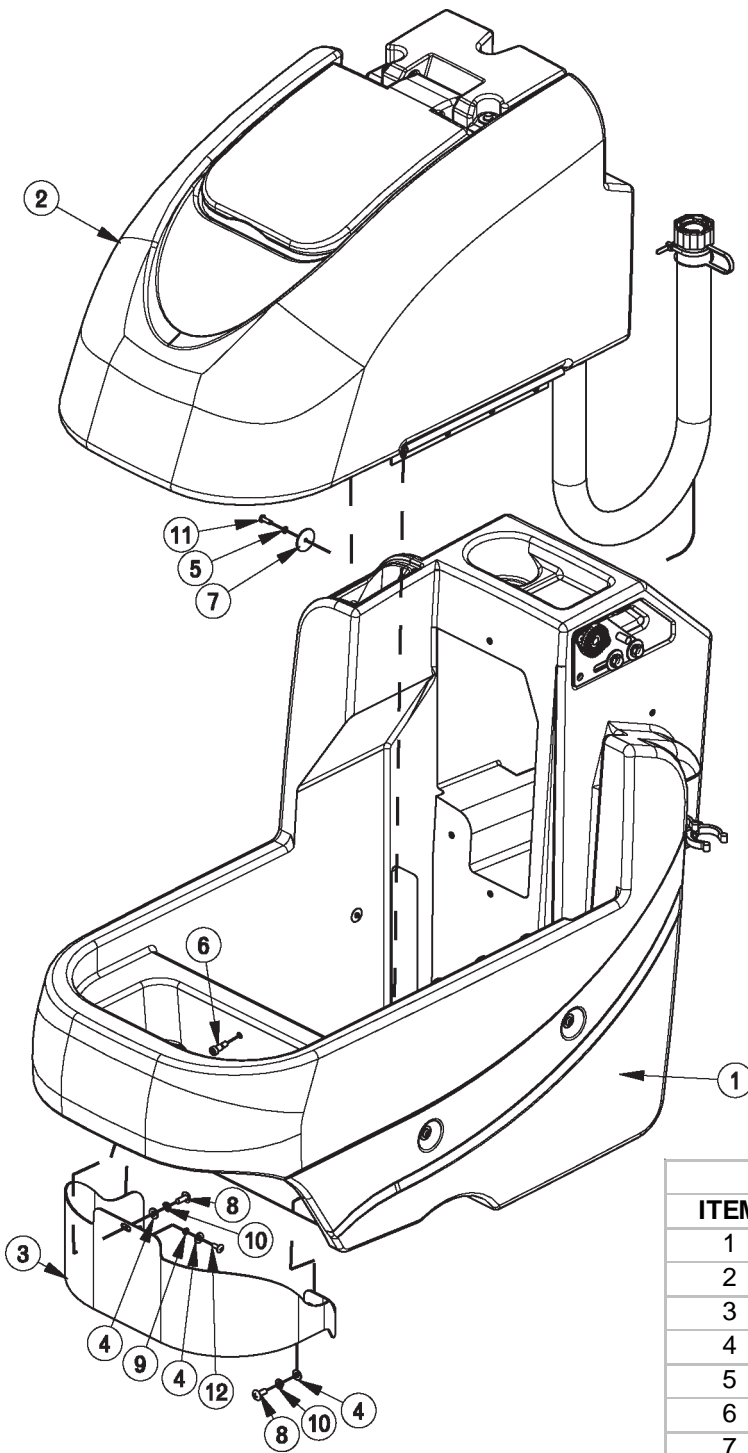

BILL OF MATERIAL - 172001BASE

ITEM	PART NO.	REQ'D	DESCRIPTION
1	172013	1	SOL TANK ASSY, E1720
2	172014	1	REC TANK ASSY
3	172144	1	PANEL, FRONT 1720
4	711504	3	WSR-FLAT 1/4 ID SS
5	711543	4	WSR-HELICAL #10
6	712041	1	BLT- SHLDR 1/4-20 X .44 X .37
7	712312	4	WSR-FLAT .187 X 1.25
8	712565	2	SCR-MC 1/4-20X.63 SS TR HD
9	712757	1	WSR - HELICAL #10 SS
10	712758	2	WSR-HELICAL 1/4 SS
11	712812	4	SCR-MC 10-24 X .62 PPH ST PL
12	712822	1	SCR-MC TR HD 10-24 X .50 SS

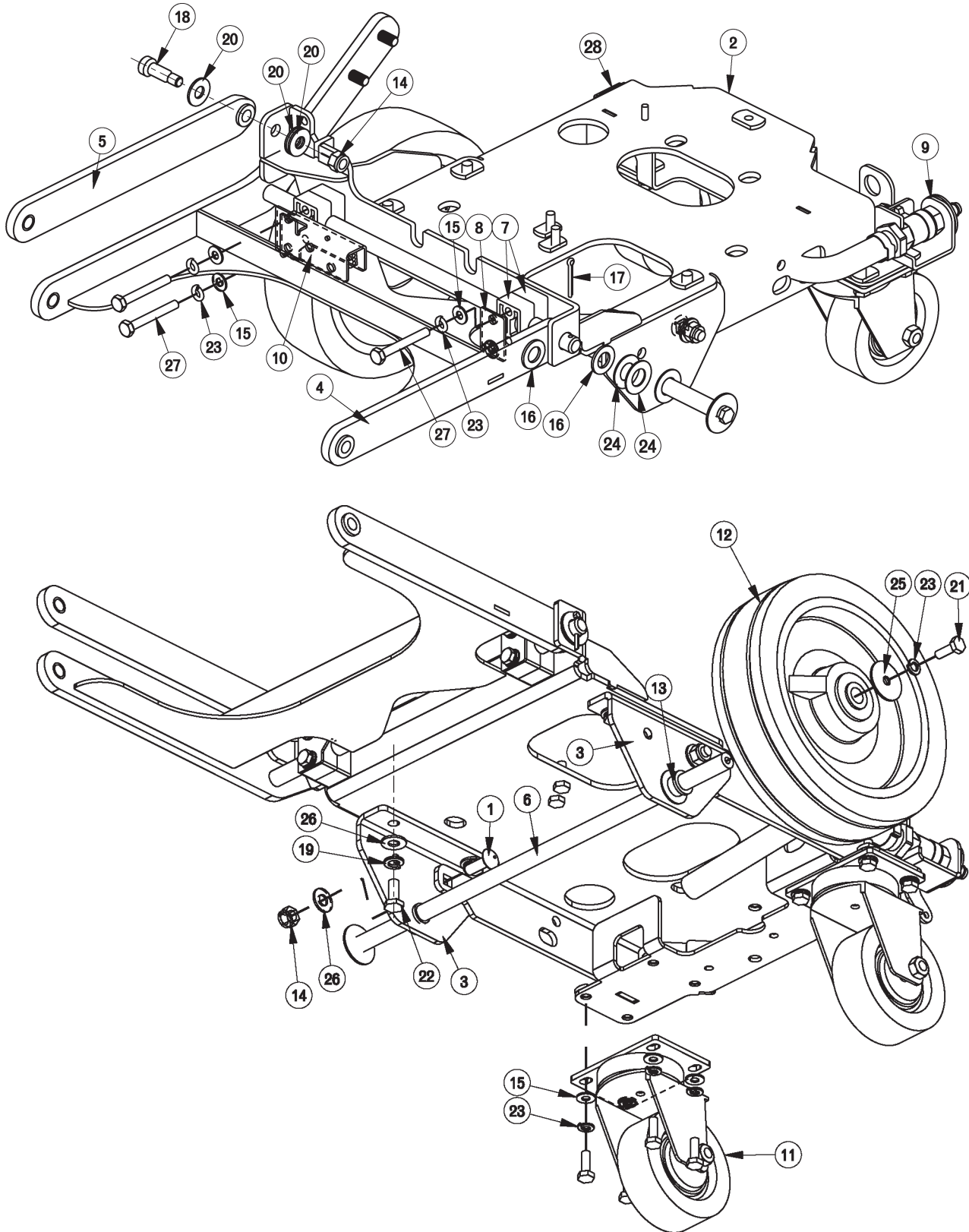

BILL OF MATERIAL - 172002 / 172002-1			
ITEM	PART NO.	REQ'D	DESCRIPTION
1	70-516-16	2	BLT-CAR 5/16-18 X 1.00
2	172020	1	MAIN FRAME WMNT, ES1720
3	172024	2	WHEEL BRACKET, ES1720
4	172025	1	DECK LIFT ASSY
5	172030	1	BAR, UPPER DECK LIFT W/ BUSH
6	172035	1	WHEEL ROD, ES1720
7	172038	4	BEARING BLOCK
8	172039	1	BEARING BLOCK PLATE
9	172064	1	SOLUTION VALVE ASSY
10	172110	1	DECK SWITCH ASSY
11	172167	2	CASTER, 3-1/2 POLYURETHANE
12	172130	2	WHEEL 8 X 2.0 X .5 BORE, E17
12A	172265	2	WHEEL, 8 X 2 X .5, 75A, E20
13	260041	2	OILITE FLANGE BUSHING
14	711374	3	NUT-NYLOC 5/16-18
15	711504	12	WSR-FLAT 1/4 ID SS
16	711592	2	WSR-FLAT .50 X .9 X .075 NYL
17	711809	1	COTTER PIN, 1/8 X 1.0
18	712081	1	SHOULDER BLT 5/16-18 X 3/8 X .75
19	712140	4	WSR-HELICAL 5/16 SS
20	712301	3	WSR-FLAT .37 X .87 X .06
21	712562	12	BOLT-HH 1/4-20X3/4 SS
22	712575	4	BLT-HH 5/16-18 X .75 SS
23	712758	14	WSR-HELICAL 1/4 SS
24	712760	4	WSR-FLAT .56X1.06X.04 SS
25	712761	2	WSR-FLAT .28 X 1.25 X .059SS
26	712772	6	WSR-FLAT .344 x .75 x .06 SS
27	713007	4	BLT-HH 1/4-20 X 2 #5
28	809444	1	CLIP-CORD

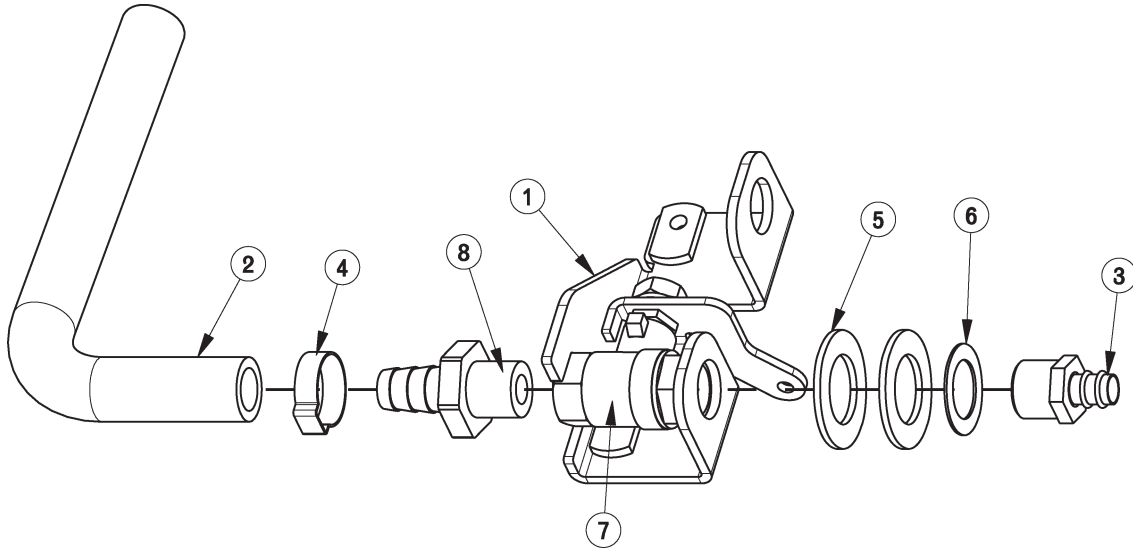

BILL OF MATERIAL - 172064			
ITEM	PART NO.	REQ'D	DESCRIPTION
1	172063	1	BKT, SOL VALVE MOUNT
2	172158	1	HOSE, 1/2"ID X 7.5" NYLOBRAID
3	320265	1	FITTING DUBL 3/8HBx3/8MPT
4	383347	1	CRIMP CLAMP 1/2 HOSE SS 185R
5	711512	2	WSR-FLAT .75X1.37X.08
6	711513	1	WSR-FLAT .69 X 1.06 X .03 SS
7	809415	1	VALVE, 3/8 FPT, 45 OPEN/CLOSE
8	827008	1	FITTING, 3/8 MPT 1/2 HOSE

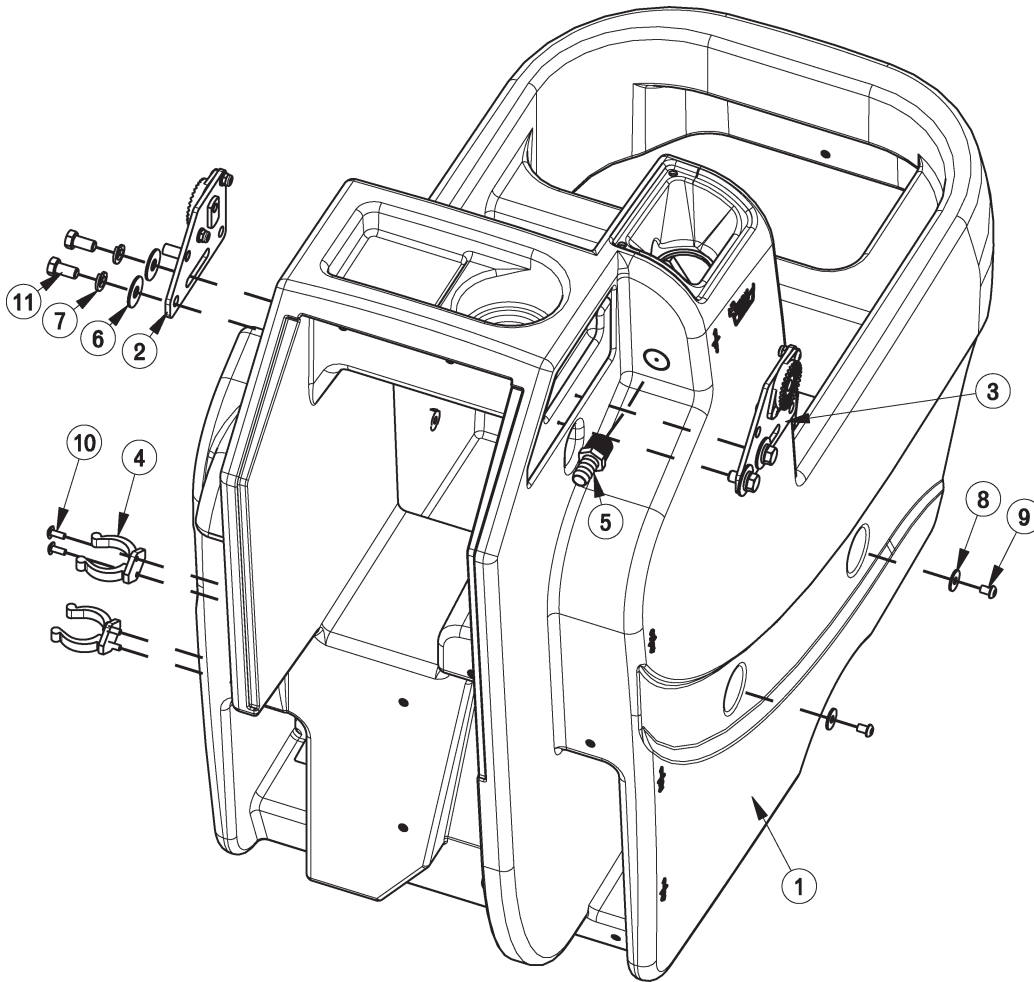

BILL OF MATERIAL - 172013

ITEM	PART NO.	REQ'D	DESCRIPTION
1	172003	1	SOLUTION TANK, ES1720
2	172080	1	HANDLE MOUNT ASSY, LEFT
3	172082	1	HANDLE MOUNT ASSY, RIGHT
4	260579	2	TOOL CLIP, 1.5" HOSE
5	342438	1	FITTING, 1/2 MPT 1/2 HB BRASS
6	711507	4	WSR-FLAT .37 X 1.12 X .06
7	711546	4	WSR-HELICAL 3/8
8	711550	4	WSR NYLON .25 ID X .75 OD
9	712146	4	SCR-SC BHCS 1/4-20 X .37 SS
10	712822	4	SCR-MC TR HD 10-24 X .50 SS
11	713041	4	BLT-HH 3/8-16 X 3/4 #5

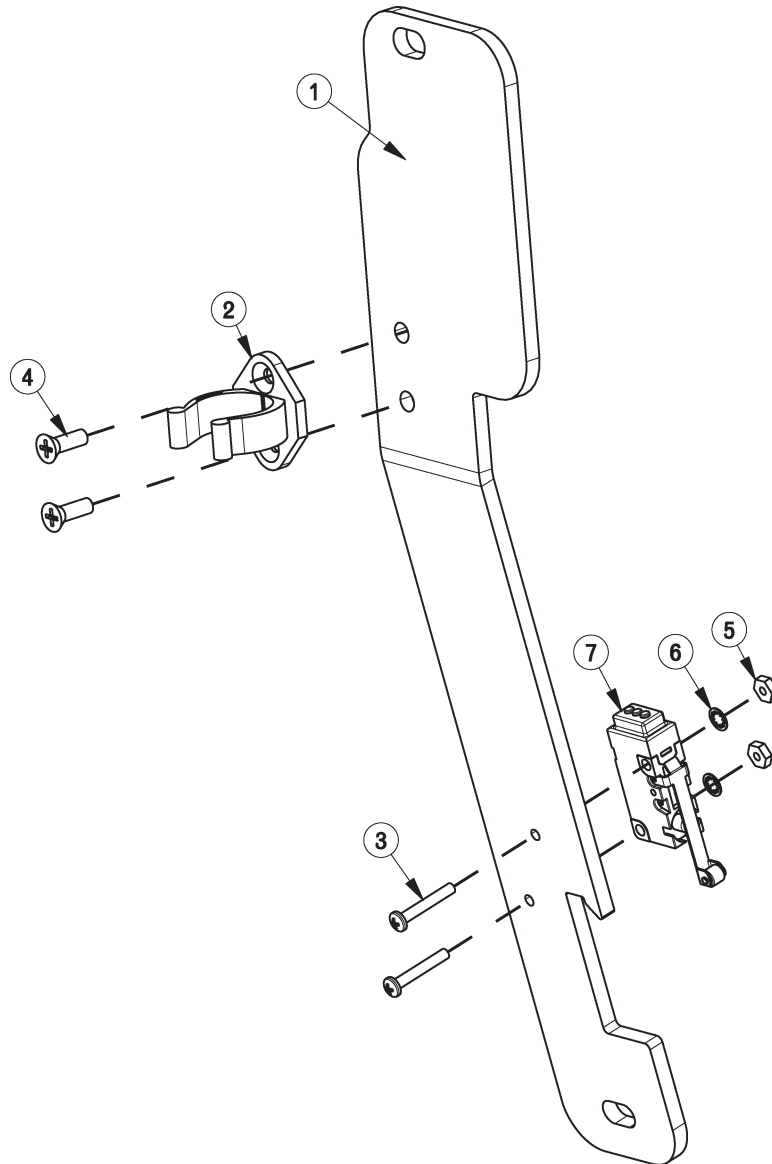

BILL OF MATERIAL - 172157			
ITEM	PART NO.	REQ'D	DESCRIPTION
1	172036	1	BKT, PEDAL STOP
2	172065	1	CLIP, FOR 1/2" ID HOSE
3	710493	2	SCR-MC 4-40 X .75 PAN HD
4	710530	2	SCR-MC FL HD 8-32 X .50 BRS
5	711428	2	NUT-HEX 4-40
6	712326	2	WSR-INT LOCK #4
7	747603-2	1	SWITCH ASY, MICRO ROLLER W/PACK/CONDUIT

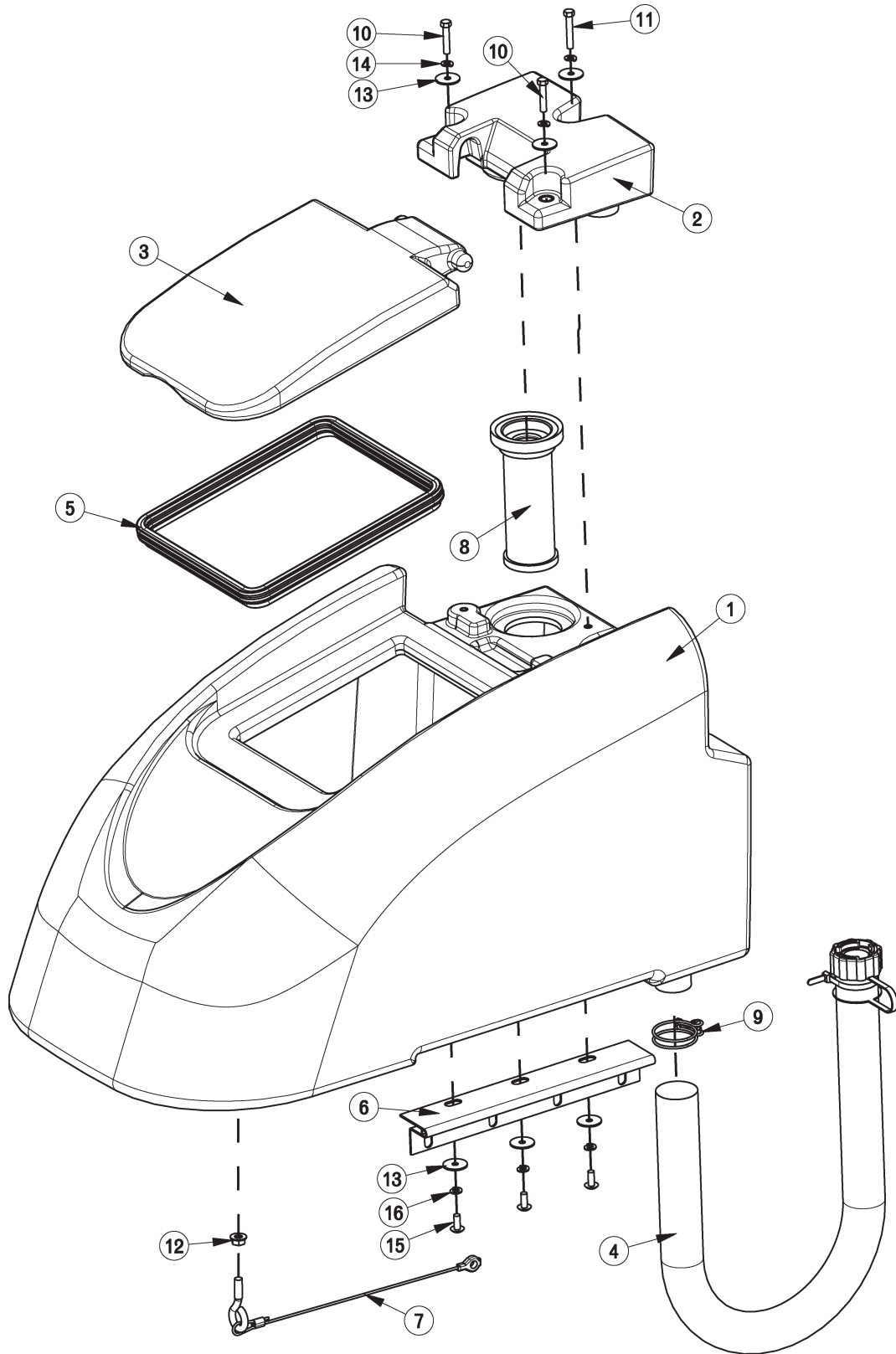

BILL OF MATERIAL - 172014			
ITEM	PART NO.	REQ'D	DESCRIPTION
1	172004	1	ES1720 RECOVERY TANK
2	172005	1	ES1720 VACUUM MANIFOLD
3	172007	1	ES1720 LID
4	172011	1	HOSE, PINCH-OFF W/ CAP, 36"
5	172017	1	GASKET, LID
6	172049	1	HINGE, RECOVERY TANK
7	172067	1	REC TANK CABLE ASSY 11.625
8	172132	1	SCREENED FLOAT
9	260203	1	WIRE GRIP HOSE CLAMP
10	711210	2	BLT-HH 1/4-20 X 1.25 STPL
11	711212	1	BLT-HH 1/4-20 X 1.50 STPL
12	711379	1	NUT, FLANGED WIZZ 5/16-18
13	711519	6	WSR- FLAT .25 X 1.01 X .06
14	711544	3	WSR-HELICAL 1/4
15	712565	3	SCR-MC 1/4-20X.63 SS TR HD
16	712758	3	WSR-HELICAL 1/4 SS

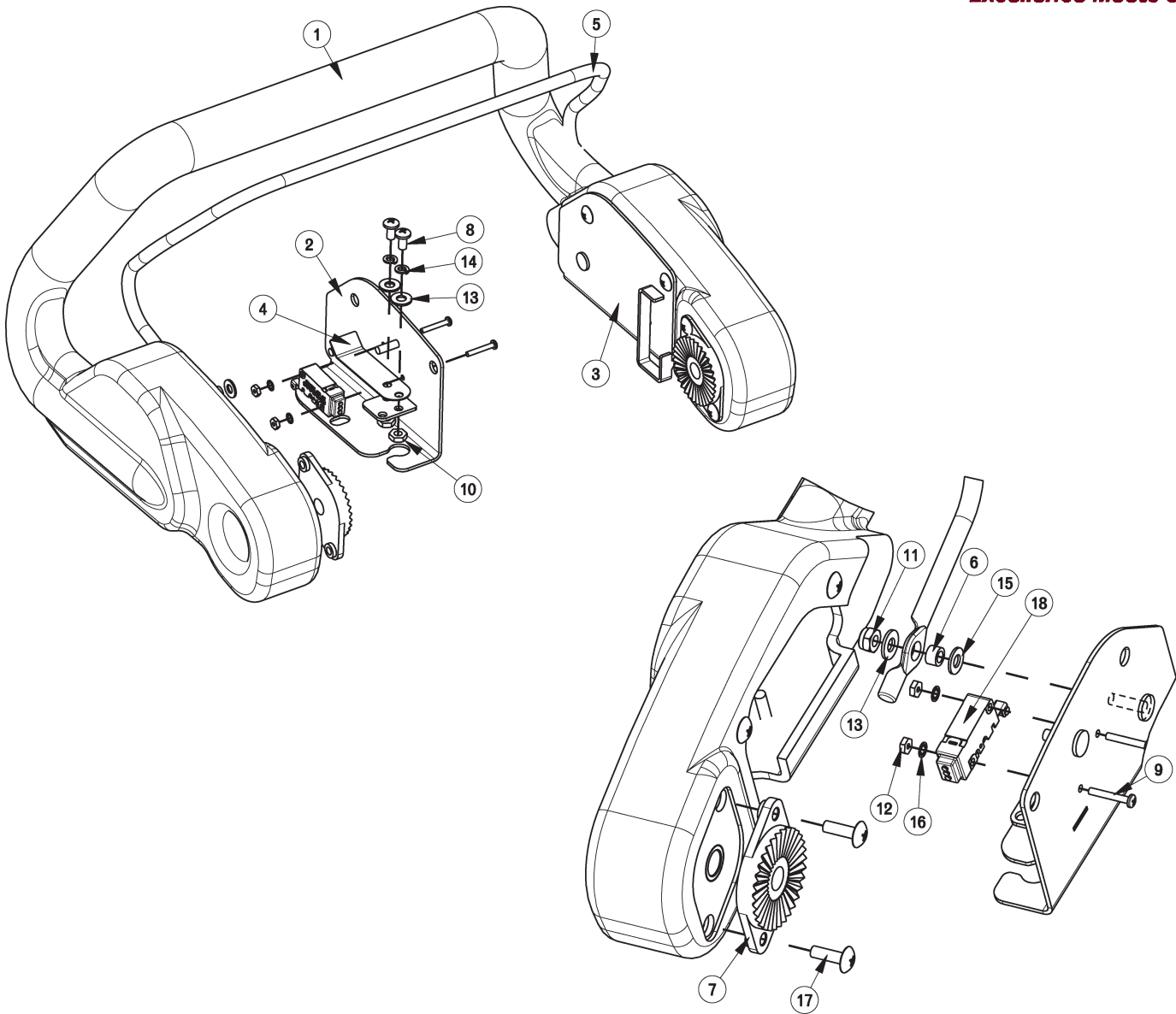

BILL OF MATERIAL - 172016			
ITEM	PART NO.	REQ'D	DESCRIPTION
1	172006	1	ES1720 HANDLE
2	172053	1	BAIL PLATE WMT RH
3	172054	1	BAIL PLATE WMT LH
4	172057	2	ES1720 LEAF SPRING
5	172059	1	ES1720 BAIL, HANDLE
6	172074	2	SPACER, 5/16OD X 17GA, ALUM
7	270143	2	HANDLE PIVOT JAW
8	710353	4	SCR-MC RD HD 10-32 X .37 STL
9	710493	2	SCR-MC 4-40 X .75 PAN HD
10	711310	4	NUT, HEX 10-32 ST PL
11	711350	2	NUT-NYLOC 10-32
12	711428	2	NUT-HEX 4-40
13	711503	6	WSR, FLAT#10
14	711543	4	WSR-HELICAL #10
15	712320	2	WSR-NYLON .22 X .45 X .04
16	712326	2	WSR-INT LOCK #4
17	712830	10	SCR-MC 10-24 X .62 STLZ TR HD
18	747603-1	1	SWITCH ASY, MICRO ROLLER W/PACK/CONDUIT
19	747632	1	CABLE ASY, 5 COND 18G CONSOLE

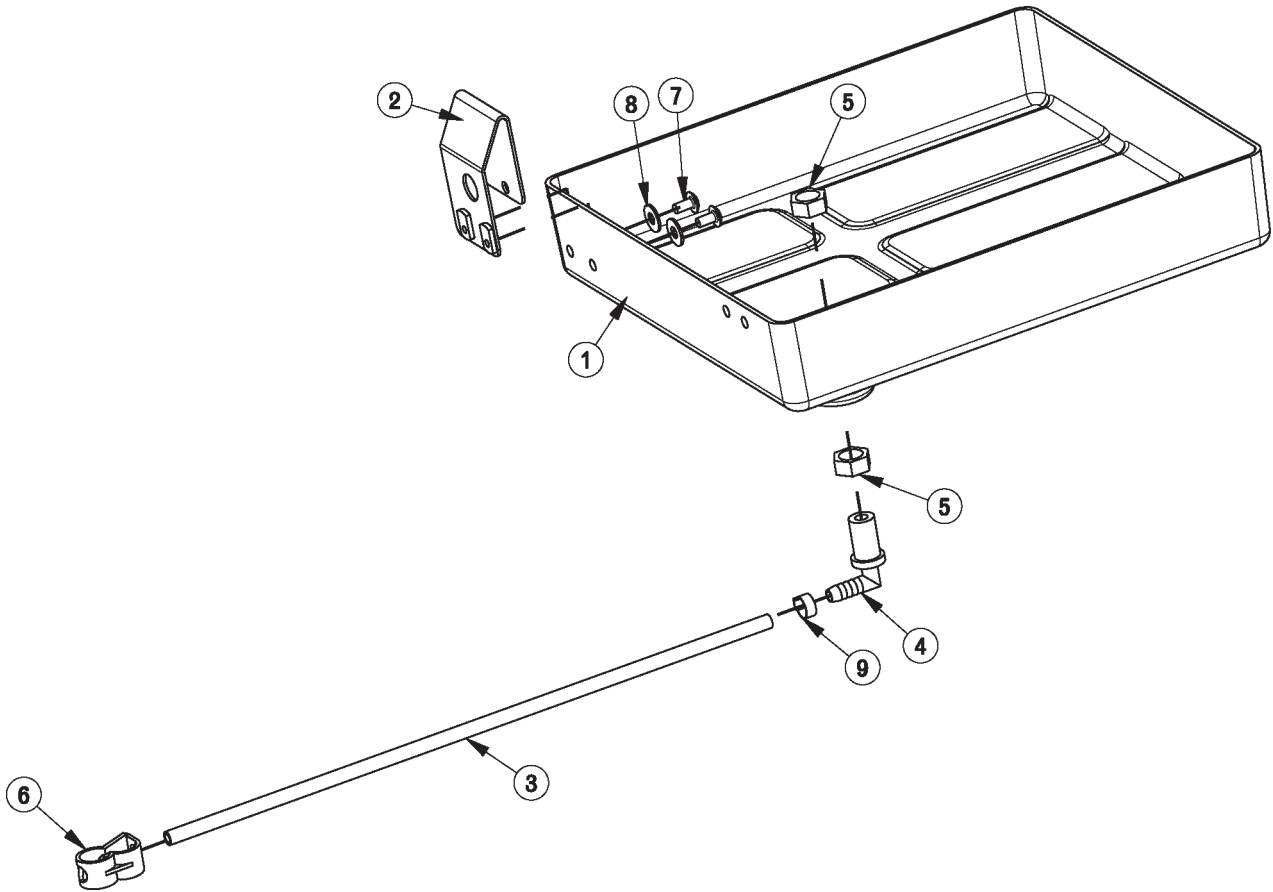

BILL OF MATERIAL - 172012			
ITEM	PART NO.	REQ'D	DESCRIPTION
1	172116	1	ES1720 BATTERY BOX
2	172213	1	BKT, SPACER FOR BATTERIES
3	260224	1	18" HOSE
4	320271	1	NOZZLE BODY-ELBOW
5	320272	2	NOZZLE BODY LOCKNUT
6	320273	1	HOSE SHUT-OFF CLAMP
7	710178	2	SCR-MC 1/4-20 X .50 TRUSS STPL
8	711575	2	WSR-FLT .31x.75x.06ST
9	828490	1	CRIMP CLAMP 140R

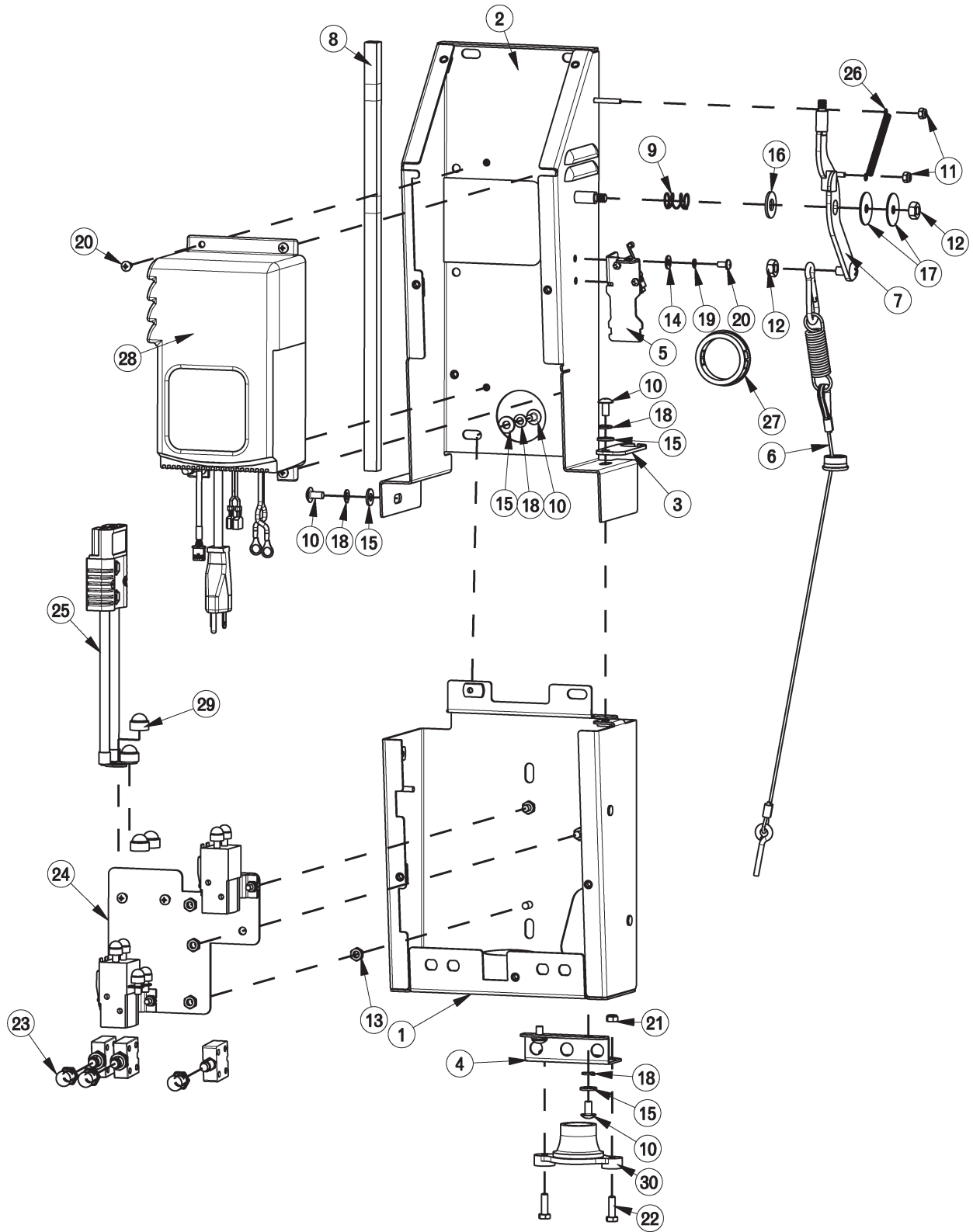

BILL OF MATERIAL - 172070-120/230			
ITEM	PART NO.	REQ'D	DESCRIPTION
1	172077	1	ELEC BOX-BOT HALF WMT
2	172088	1	ELEC BOX-TOP HALF WMT
3	172107	1	BKT, UPPER BUSHING MOUNT
4	172128	1	BKT, LOWER BUSHING MOUNT
5	172141	1	VAC SWITCH ASSY
6	172149	1	CABLE ASSY, SQUEEGEE LIFT
7	172152	1	VAC LEVER WMT
8	172188	1	FOAM TAPE, 1/2" SQ X 16.5"
9	670093	1	SPRING, COMPRESSION
10	710178	5	SCR-MC 1/4-20 X .50 TRUSS STPL
11	711372	2	NUT-NYLOC 8-32 STL ZINC
12	711383	2	NUT-HEX CLR LOC 5/16-18
13	711429	6	NUT-HEX 1/4-28 JAM STL Z
14	711503	2	WSR, FLAT#10
15	711505	5	WSR-FLAT 1/4
16	711508	1	WSR-FLAT .44X 1.0X.08
17	711516	2	WSR- FLAT .31 X 1.25 X .05
18	711544	5	WSR-HELICAL 1/4
19	712757	2	WSR - HELICAL #10 SS
20	712810	6	SCR-MC 10-24 X .37 ST PL
21	717018	2	NUT-NYLOC M6 X 1.0
22	717022	2	BOLT-HH M6X1.0 X 20
23	742748	3	CIRCUIT BREAKER BOOT
24	747630	1	ELEC PANEL ASSY, E1720BD
25	747637	1	WIRE ASY, MACHINE-BATTERY E1720
26	762084	1	SPRING-EXT
27	762400	1	HEYCO BUSHING 2.00"
28	957745	1	CHARGER,24VDC 12A ON-BOARD 120VAC
28A	957753	1	CHARGER,24VDC 12A ON-BOARD 230VAC
29	15592033	2	CAP, SAFETY NUT COVER M8
30	90508391	1	BUSHING, CABLE GUIDE, HAKO

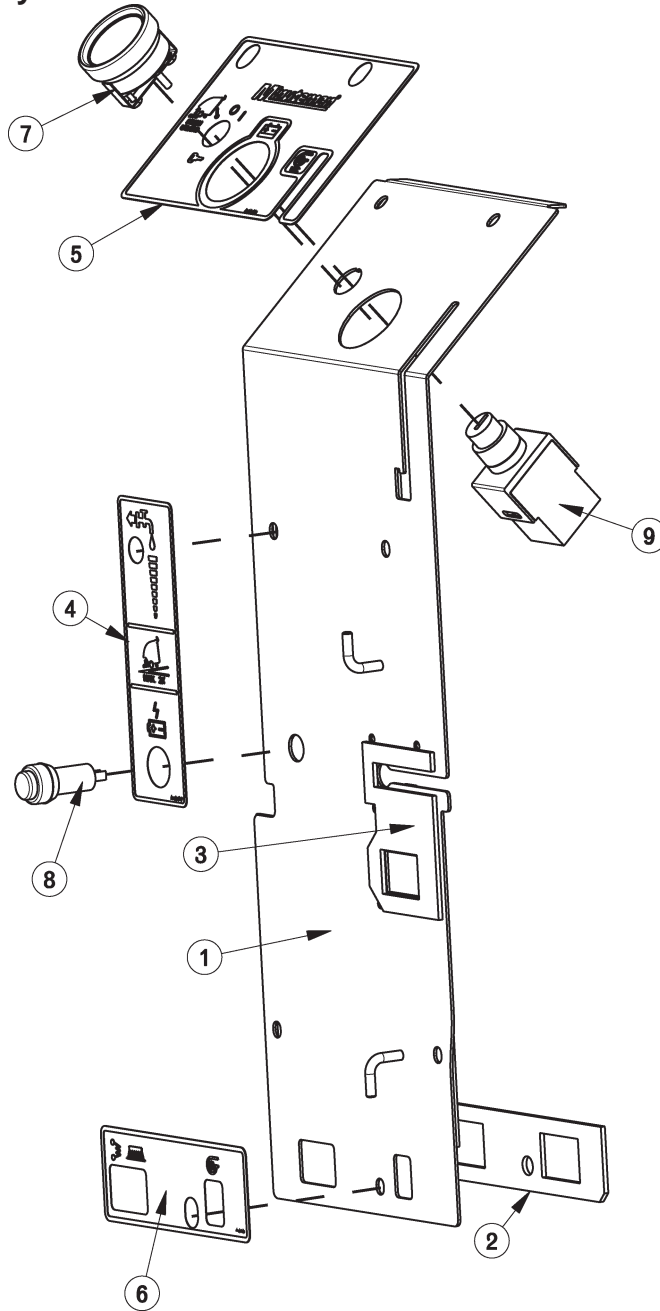

BILL OF MATERIAL - 172073			
ITEM	PART NO.	REQ'D	DESCRIPTION
1	172181	1	ELEC BOX, COVER, WMT
2	172193	1	GASKET, CB OUTLINE
3	172194	1	GASKET, CHARGER CORD PLATE
4	715672	1	DECAL, 1720 BD ELEC BOX
5	715673	1	DECAL, 1720 BD DASHBOARD
6	715675	1	DECAL, BD CIRC BKRS
7	740216	1	VOLT METER
8	747614	1	CHARGE STATUS INDICATOR
9	747617-1	1	KEYSWITCH ASY, KEYSWITCH + WIR

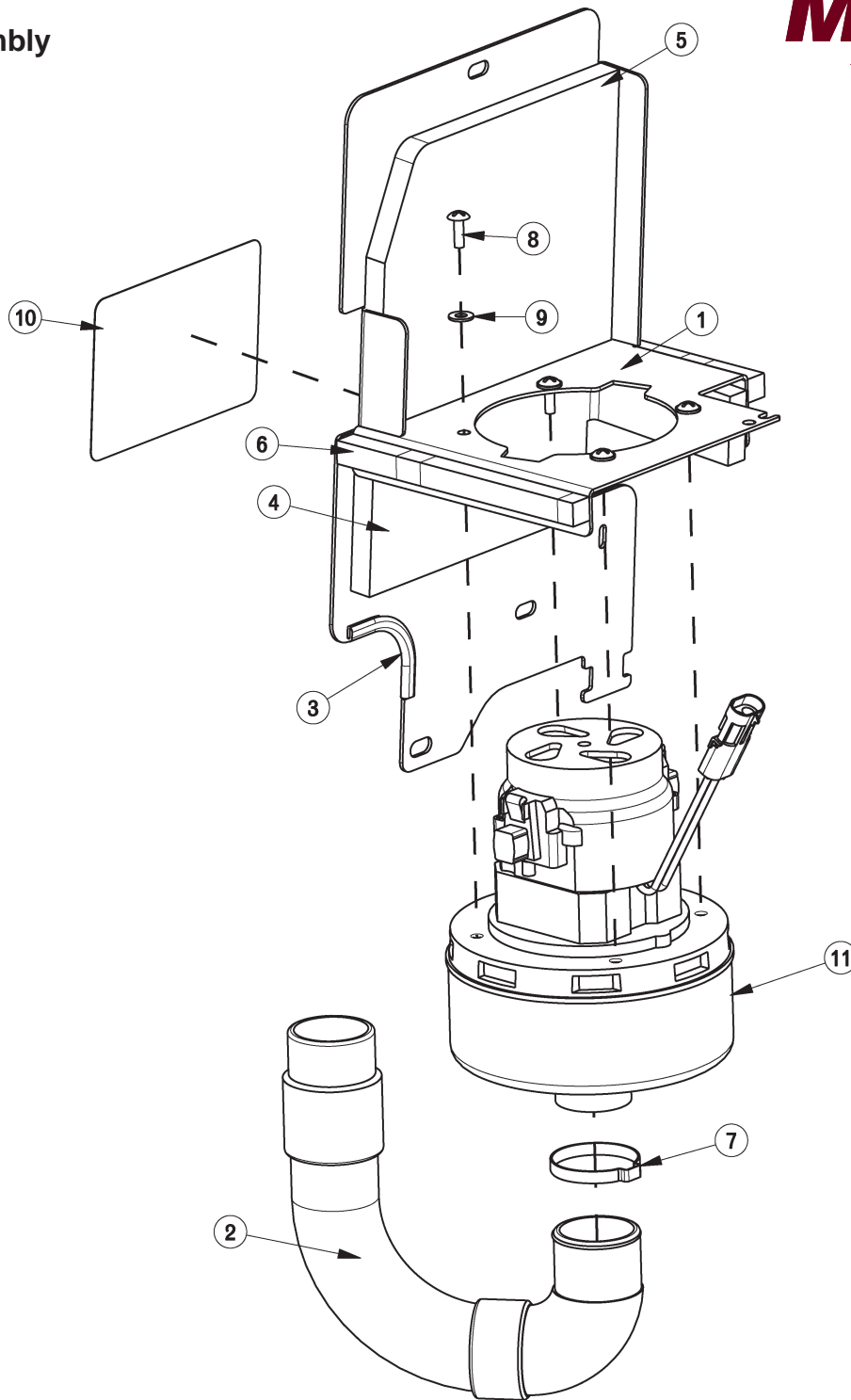

BILL OF MATERIAL - 172050

ITEM	PART NO.	REQ'D	DESCRIPTION	ITEM	PART NO.	REQ'D	DESCRIPTION
1	172045	1	VAC MOUNT WMT, ES1720	7	450095	1	CRIMP CLAMP, 1.75"
2	172048	1	HOSE, STRETCH 13"	8	711160	4	#10 X 5/8 HI-LO
3	172124	1	EDGE TRIM, .063 X 3.0, BLACK	9	711503	4	WSR, FLAT#10
4	172186	1	FOAM COVER, FRONT 1	10	715676	1	DECAL, BATT CABLE ROUTE, E1720
5	172187	1	FOAM COVER, FRONT 2	11	747607-1	1	VAC MOTOR ASY, E1720
6	172188	2	FOAM TAPE, 1/2" SQ X 16.5"				

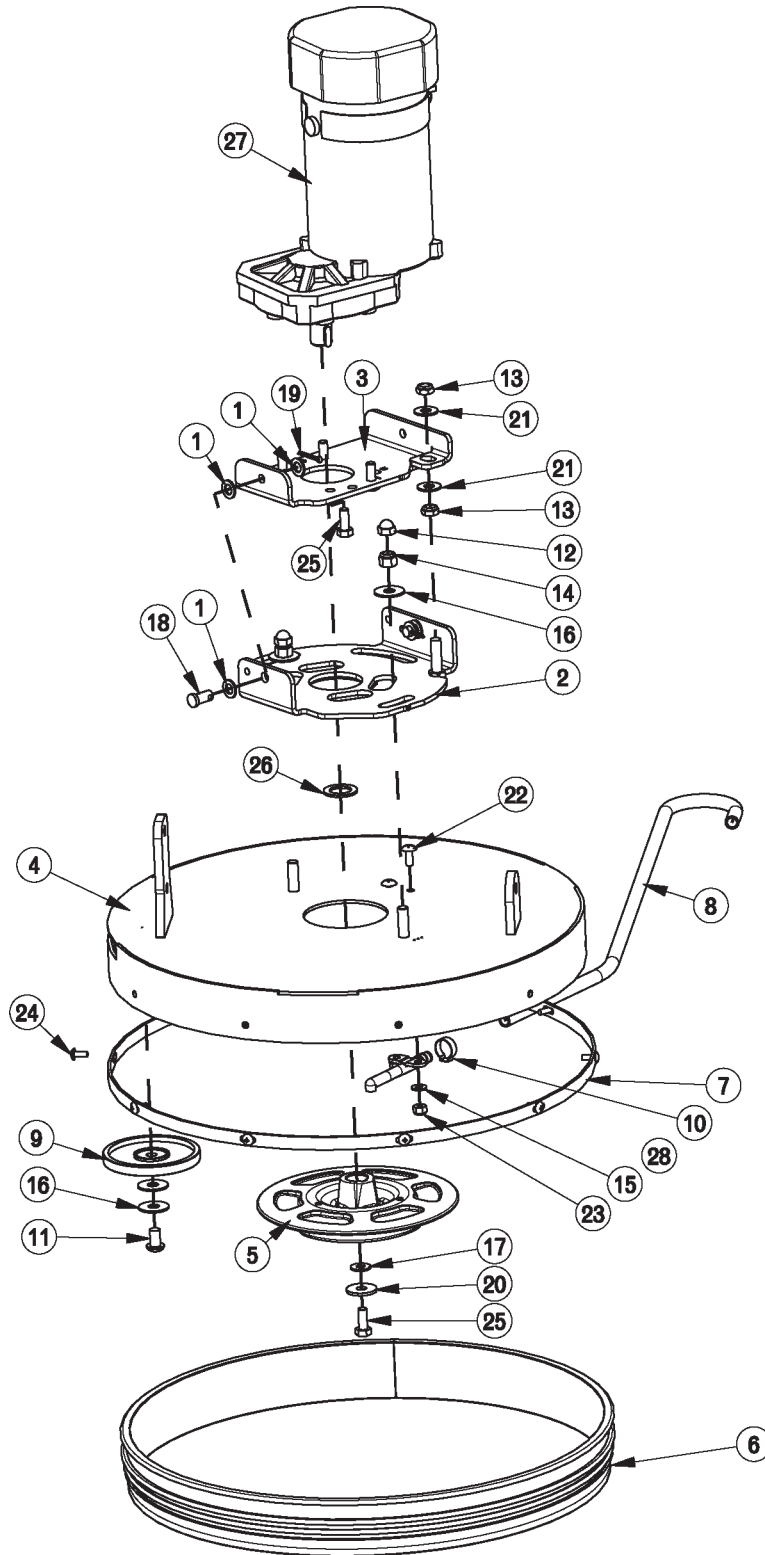

BILL OF MATERIAL - 172090			
ITEM	PART NO.	REQ'D	DESCRIPTION
1	81-166-A	6	SPECIAL WASHER
2	172040	1	DECK ANGLE ADJUST WMT
3	172044	1	PLATE, MOTOR MOUNT
4	172091	1	DECK COVER WMT 17"
5	172095	1	E20 BRUSH HUB ASSY
6	172118	1	17" DECK SKIRT
7	172119	1	RETAINER, 17" DECK SKIRT
8	172216	1	HOSE-WIRE REINF 3/8 X 29"
9	210153	1	ROLLER WHEEL
10	450076	1	CLAMP-CRIMP 185R SS
11	710985	1	SCR-SC 3/8-16 X .62 ST PL
12	711354	2	NUT-ACORN 3/8-16 ST NI
13	711375	2	NUT-NYLOC 3/8-16 X 1/2 NUT
14	711380	2	NUT-NYLOC 3/8-16 NUT
15	711504	2	WSR-FLAT 1/4 ID SS
16	711507	4	WSR-FLAT .37 X 1.12 X .06
17	711575	1	WSR-FLT .31x.75x.06ST
18	711679	2	CLEVIS PIN 3/8 X 3/4
19	711809	2	COTTER PIN, 1/8 X 1.0
20	711855	1	WSR-FLT .37X1.12X10 STL Z HARD
21	712301	2	WSR-FLAT .37 X .87 X .06
22	712565	2	SCR-MC 1/4-20X.63 SS TR HD
23	712667	2	NUT, HEX 1/4-20 NYLOC SS
24	712822	10	SCR-MC TR HD 10-24 X .50 SS
25	717024	5	BOLT-HH M8X1.25 X 20
26	717025	1	WSR-FLAT 13/16ID X 1.25 X .08
27	747600	1	MOTOR, OFFSET PM GEAR, 550W
28	90311663	1	HAKO SOL FEED NOZZLE

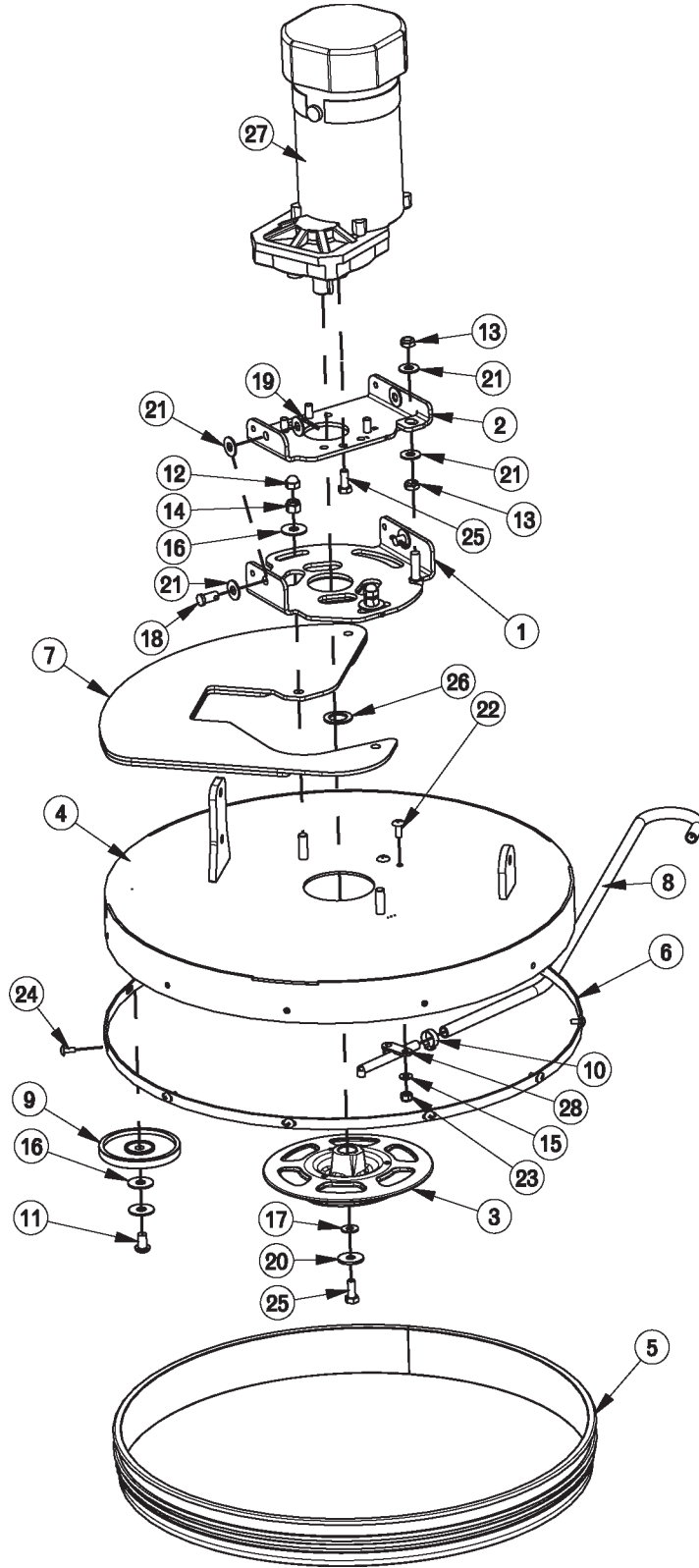

BILL OF MATERIAL - 172100			
ITEM	PART NO.	REQ'D	DESCRIPTION
1	172040	1	DECK ANGLE ADJUST WMT
2	172044	1	PLATE, MOTOR MOUNT
3	172095	1	E20 BRUSH HUB ASSY
4	172101	1	DECK COVER WMT 20"
5	172121	1	20" DECK SKIRT
6	172125	1	RETAINER, 20" DECK SKIRT
7	172208	1	E20 BRUSH DECK PLATE
8	172216	1	HOSE-WIRE REINF 3/8 X 29"
9	210153	1	ROLLER WHEEL
10	450076	1	CLAMP-CRIMP 185R SS
11	710985	1	SCR-SC 3/8-16 X .62 ST PL
12	711354	2	NUT-ACORN 3/8-16 ST NI
13	711375	2	NUT-NYLOC 3/8-16 X 1/2 NUT
14	711380	2	NUT-NYLOC 3/8-16 NUT
15	711504	2	WSR-FLAT 1/4 ID SS
16	711507	4	WSR-FLAT .37 X 1.12 X .06
17	711575	1	WSR-FLT .31x.75x.06ST
18	711679	2	CLEVIS PIN 3/8 X 3/4
19	711809	2	COTTER PIN, 1/8 X 1.0
20	711855	1	WSR-FLT .37X1.12X.10 STL Z HARD
21	712301	8	WSR-FLAT .37 X .87 X .06
22	712565	2	SCR-MC 1/4-20X.63 SS TR HD
23	712667	2	NUT, HEX 1/4-20 NYLOC SS
24	712822	11	SCR-MC TR HD 10-24 X .50 SS
25	717024	5	BOLT-HH M8X1.25 X 20
26	717025	1	WSR-FLAT 13/16ID X 1.25 X .08
27	747600	1	MOTOR, OFFSET PM GEAR, 550W
28	90311663	1	HAKO SOL FEED NOZZLE

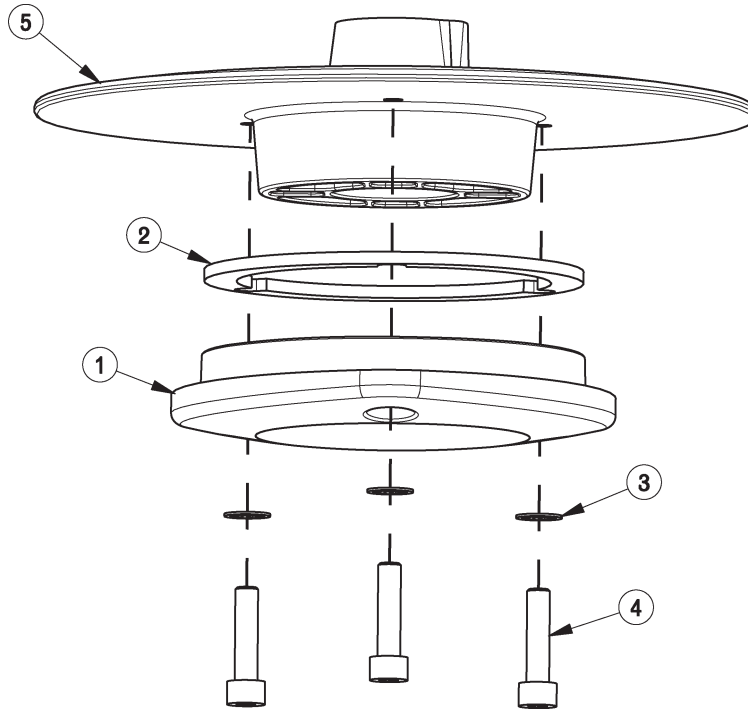

BILL OF MATERIAL - 172095			
ITEM	PART NO.	REQ'D	DESCRIPTION
1	172097	1	ES1720 BRUSH HUB BASE
2	172133	1	BRUSH HUB SPACER
3	711554	3	WSR-INTERNAL LOCK 1/4 ID
4	717026	3	SCR-SC SHCS M6X1.0 X 25 STL Z
5	172096MCH	1	BASE, DRIVE HUB WITH KEYWAY

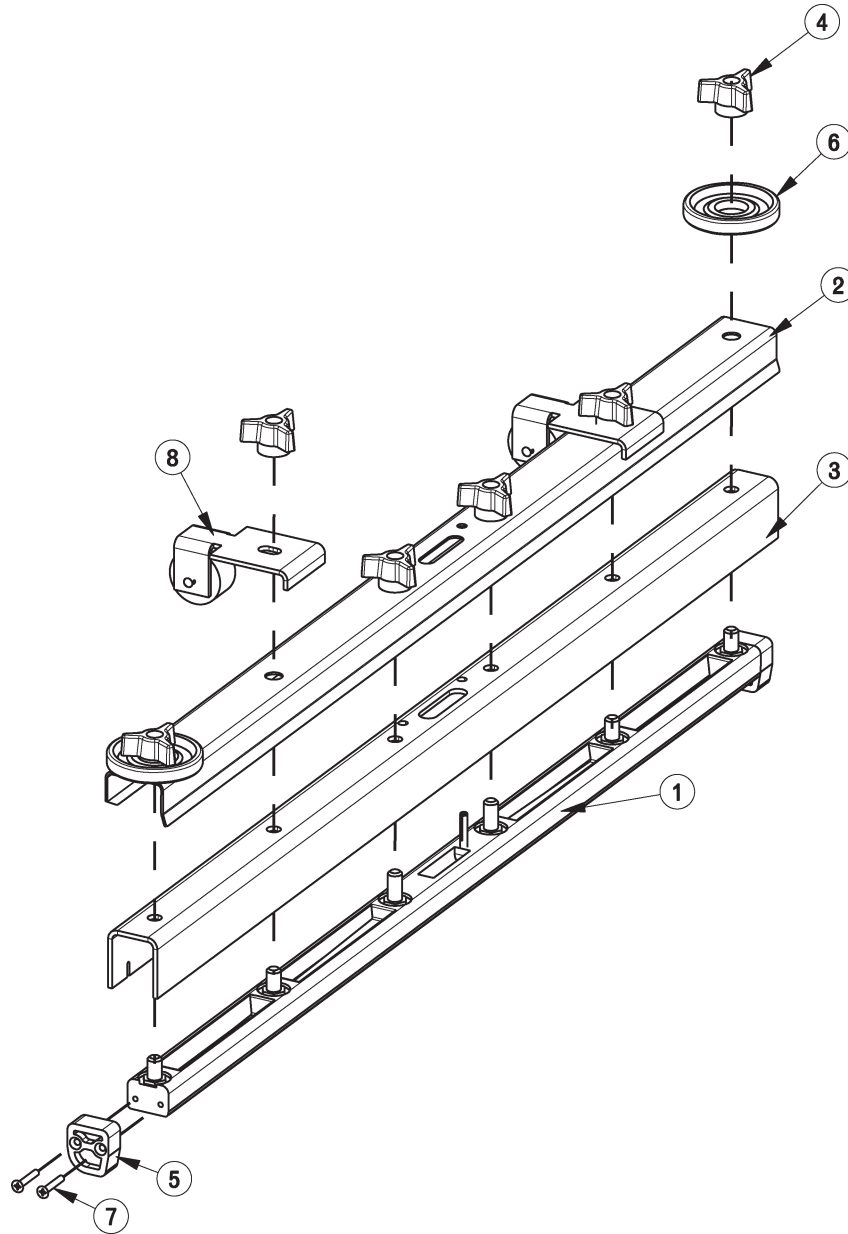

BILL OF MATERIAL			
ITEM	PART NO.	REQ'D	DESCRIPTION
1	210023	1	SQUEEGEE CASTING ASY
2	210024	1	SQUEEGEE MOUNT BKT
3	210065	1	SQUEEGEE BLADE 200 GUM
4	430074	6	ADJUSTING NUT 17B/E
5	430076	2	NYLON SQUEEGEE INSERT
6	430085	2	SQUEEGEE BUMPER WHEEL
7	712517	4	SCR-MC 8-32 X 1" ST PL - PH
8	831400	2	WHEEL ASSY

E20 Rear Squeegee Assembly

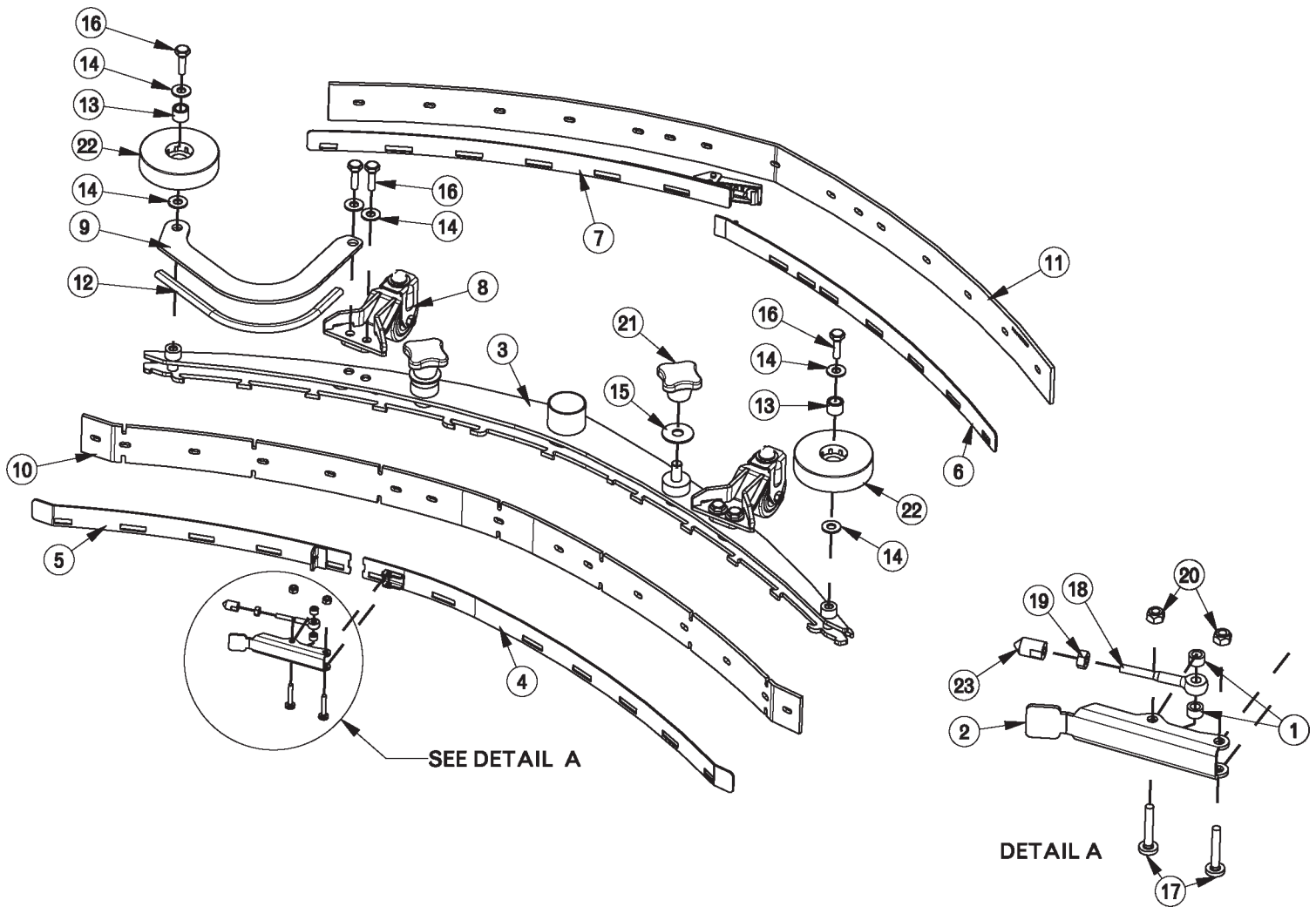

BILL OF MATERIAL - 172270

ITEM	PART NO.	REQ'D	DESCRIPTION	ITEM	PART NO.	REQ'D	DESCRIPTION
1	172074	2	SPACER, 5/16OD X 17GA, ALUM	12	172274	1	EDGE TRIM 5/16 X 10" BLACK
2	172234	1	LEVER, 90535758	13	430322	2	BUSHING .435 X .625 X .50
3	172235	1	SQUEEGEE WMT, 34" (860)	14	712772	8	WSR-FLAT .344 x .75 x .06 SS
4	172240	1	STRAP WMT, FRONT LEFT	15	712773	2	WSR FLAT .438 X 1.25 X .07 SS
5	172241	1	STRAP WMT, FRONT	16	11039567	6	BLT-HH M8 X 25 SS DIN933
6	172245	1	STRAP WMT, REAR	17	11175494	2	SCR-MC M5 X 25 SS DIN7985
7	172246	1	STRAP WMT, REAR	18	11518313	1	BLT-EYE M5 X 40 SS
8	172250	2	SQUEEGEE CASTER ASSY	19	12022430	1	NUT-HEX M5 SS DIN934
9	172271	1	BUMPER, 34" SQG	20	12040283	2	NUT-HEX M5 NYLOC SS DIN985
10	172272	1	FRNT SQG BLADE 34", 1/8 PU	21	17133026	2	KNOB, M10 STAR HANDLE
10A	172282	1	SQUEEGEE, FRONT BLADE 34", 1/8 LINATEX	22	90336637	2	WHEEL, 3.15OD
11	172273	1	REAR SQG BLADE 34", 1/8 PU	23	90513631	1	PIN, THD 90513631
11A	172283	1	SQUEEGEE, REAR BLADE 34", 1/8 LINATEX				

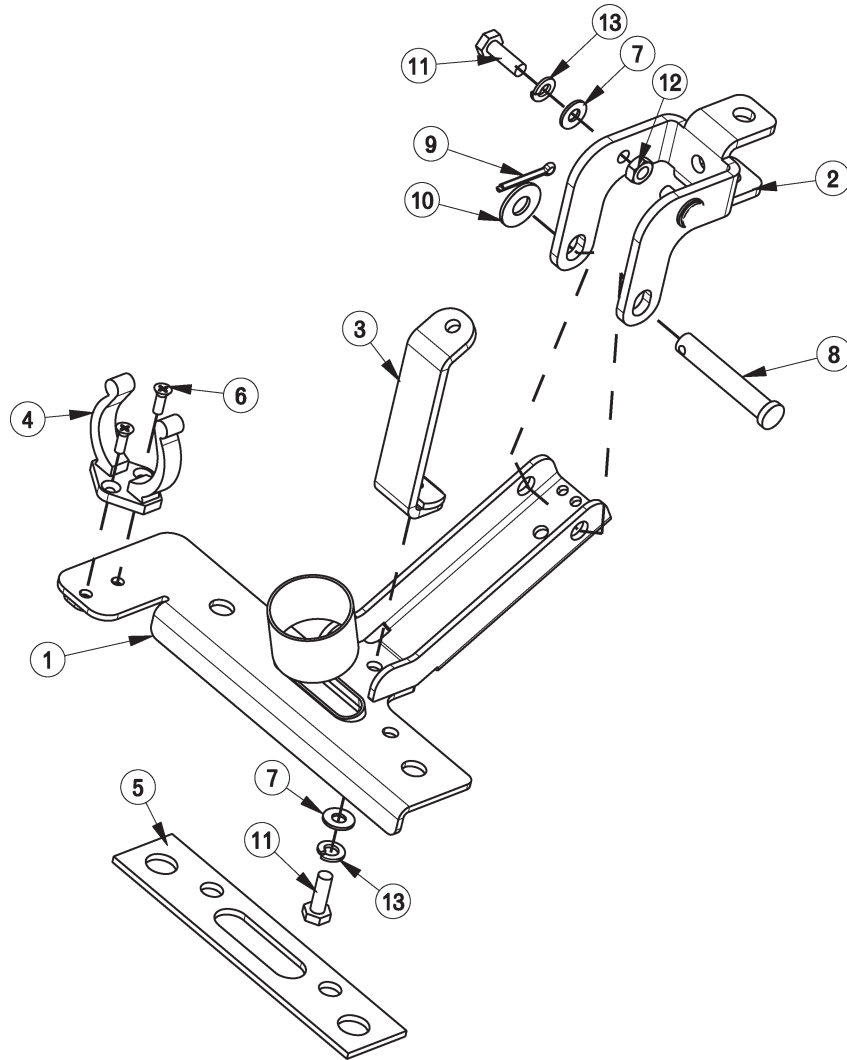

BILL OF MATERIAL - 172170			
ITEM	PART NO.	REQ'D	DESCRIPTION
1	172171	1	SQUEEGEE MECH WMT
2	172173	1	BKT, MAIN SQUEEGEE HINGE
3	172175	1	BKT, STANDOFF
4	260579	1	TOOL CLIP, 1.5" HOSE
5	430073	1	GASKET DIE CUT PS BACK
6	710530	2	SCR-MC FL HD 8-32 X .50 BRS
7	711504	3	WSR-FLAT 1/4 ID SS
8	711678	1	CLEVIS PIN 3/8 X 2-1/4
9	711809	1	COTTER PIN, 1/8 X 1.0
10	712301	1	WSR-FLAT .37 X .87 X .06
11	712562	3	BOLT-HH 1/4-20X3/4 SS
12	712665	2	NUT-HEX 1/4-20 SS
13	712758	3	WSR-HELICAL 1/4 SS

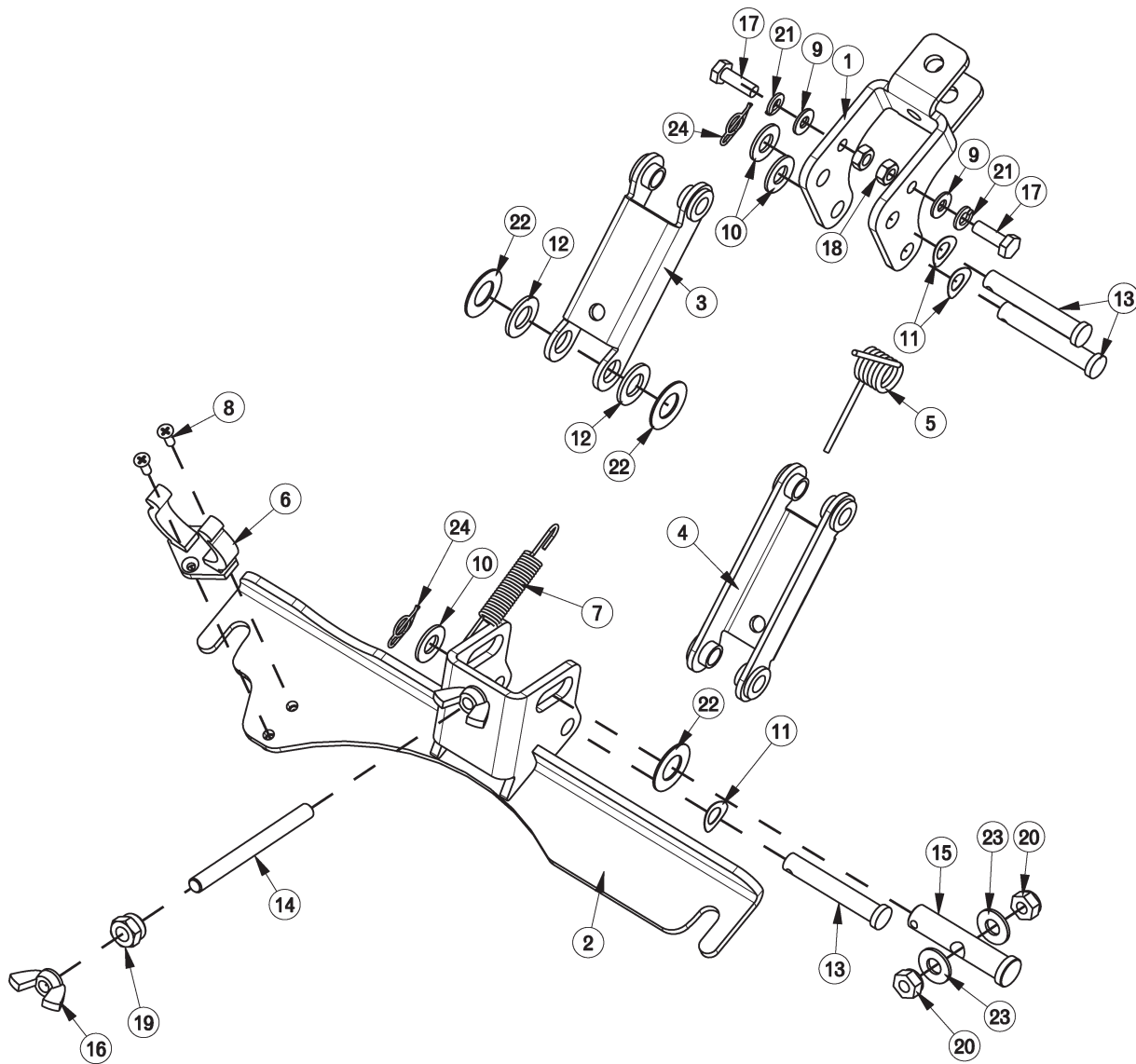

BILL OF MATERIAL - 172150

ITEM	PART NO.	REQ'D	DESCRIPTION	ITEM	PART NO.	REQ'D	DESCRIPTION
1	172134	1	BKT, MAIN SQUEEGEE HINGE	13	711678	3	CLEVIS PIN 3/8 X 2-1/4
2	172155	1	SQUEEGEE MOUNT WMT	14	712147	1	ROD-THD 5/16-18 X 3.5 SS
3	172196	1	SQ TOP LINK W/ BUSHING	15	712148	1	CLEVIS PIN, 1/2 x 2.25 W/ HOLE
4	172197	1	SQ BOT LINK W/ BUSH	16	712157	2	NUT- WING 5/16-18 SS
5	172261	1	TORSION SPRING	17	712562	2	BOLT-HH 1/4-20X3/4 SS
6	260579	1	TOOL CLIP, 1.5" HOSE	18	712665	2	NUT-HEX 1/4-20 SS
7	430051	1	RETURN SPRING-3.00"	19	712680	1	NUT-HEX 5/16-18 SS
8	710530	2	SCR-MC FL HD 8-32 X .50 BRS	20	712683	2	NUT, HEX 5/16-18 NYLOC SS
9	711504	2	WSR-FLAT 1/4 ID SS	21	712758	2	WSR-HELICAL 1/4 SS
10	711515	3	WSR-FLAT .406 X .812 X .0625	22	712760	3	WSR-FLAT .56X1.06X.04 SS
11	711523	3	WSR-WAVE .37X .68 X .08	23	712772	2	WSR-FLAT .344 x .75 x .06 SS
12	711592	2	WSR-FLAT .50 X .9 X .075 NYL	24	3400125	2	PIN-COTTER 3/8 RUE RING

1 Wiring Diagrams

PAGE LAYOUT

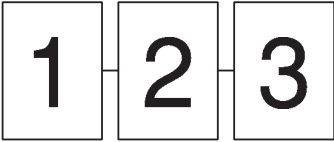

PAGES GO TOGETHER AS SHOWN TO SEE THE ENTIRE SCHEMATIC AS ONE.

ELECTRICAL BOX COVER ASSEMBLY 172073

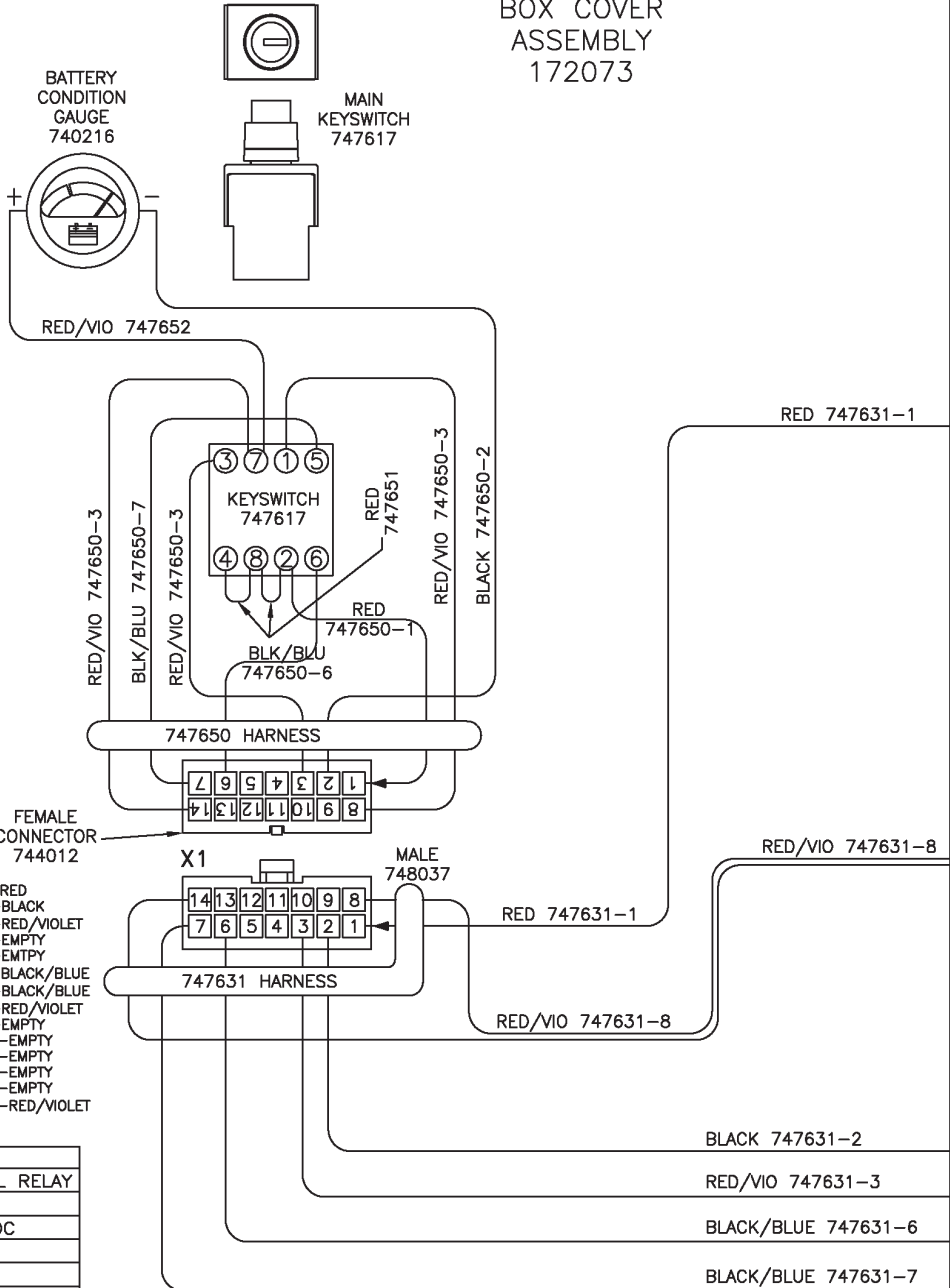

CONNECTOR NUMBERS AND NAMES

CONNECTOR #	DESCRIPTION
X1	KEYSWITCH
X2	OPERATOR HANDLE SWITCH
X3	CHARGER STATUS INDICATOR
X4	VACUUM SWITCH
X5	BATTERY CONNECTOR
X6	VACUUM MOTOR
X7	BRUSH MOTOR SWITCH
X8	BRUSH UNLOAD SWITCH
X9	OPTIONAL: SOLENOID SWITCH
X10	OPERATOR HANDLE CABLE
X11	OPERATOR HANDLE CABLE
X12	-
X13	-
X14	-
X15	ACCESSORY CONNECTION
X16	ACCESSORY CONNECTION
X17	OPTIONAL (747656 GREY/RED)
X18	OPTIONAL (747657 GREY/BLACK)

- 1-RED
- 2-BLACK
- 3-RED/VIOLET
- 4-EMPTY
- 5-EMPTY
- 6-BLACK/BLUE
- 7-BLACK/BLUE
- 8-RED/VIOLET
- 9-EMPTY
- 10-EMPTY
- 11-EMPTY
- 12-EMPTY
- 13-EMPTY
- 14-RED/VIOLET

X1: MAIN KEYSWITCH ASSEMBLY: 747617-1

PIN #	COLOR	WHERE TO/FROM
1	RED	X13: BATTERY CHARGER INTERNAL RELAY
2	BLACK	RELAY COILS: 0V
3	RED/VIOLET	BRUSH MOTOR RELAY COIL: 24VDC
4	EMPTY	-
5	EMPTY	-
6	BLACK/BLUE	BRUSH RELAY NORMALLY CLOSED
7	BLACK/BLUE	BRUSH UNLOAD SWITCH P:B
8	RED/VIOLET	X12: MAIN RELAY COIL: 24VDC
9	EMPTY	-
10	EMPTY	-
11	EMPTY	-
12	EMPTY	-
13	EMPTY	-
14	RED/VIOLET	X12: MAIN RELAY COIL: 24VDC

BATTERY CHARGER: 957745 or 957753

	COLOR	WHERE TO/FROM
X13	RED	X13: KEYSWITCH P:1
X14	BLACK	X14: CONTROL CB 4.0A
14GA	RED	MAIN RELAY + (REAR LEFT POST)
14GA	BLACK	MAIN RELAY - (FRONT LEFT POST)

OTHER WIRE COLORS

-	RED	BATTERY 24VDC: +
-	BLACK	BATTERY 0VDC: -
-	GREEN/YELLOW	GROUND
-	BLACK/BLUE	BRUSH UNLOAD CIRCUIT
-	RED/BLACK	BRUSH UNLOAD CIRCUIT: MICRO SWITCH
-	RED/VIOLET	24VDC AFTER MAIN KEYSWITCH
X15	GREY/RED	OPTIONAL POWER 24VDC: 3A MAX
X16	GREY/BLACK	OPTIONAL POWER 0VDC: 3A MAX

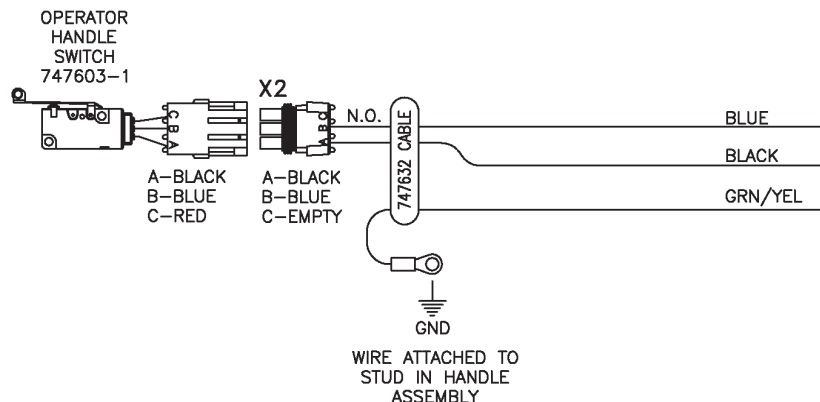

2

ELECTRICAL BOX ASSEMBLY
172070-120
172070-230

CHARGER STATUS INDICATOR
747614

X3

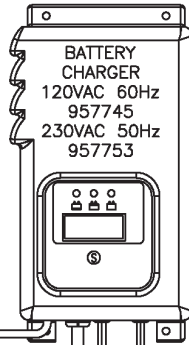

CABLE + BOARD
747614-1

TO BATTERY PACK

BLACK 747637-2

RED 747637-1



X5
740159

TO
120VAC 60Hz
or
230VAC 50Hz

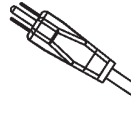

RELAY NUT COVER
MAIN RELAY M8 15592033 (4)
VACUUM RELAY M6 15592025 (2)
BRUSH MOTOR RELAY M6 155925025 (4)

*RELAY TERMINALS ARE METRIC
MAIN RELAY:M8 TORQUE TO 8-9.5Nm
VACUUM & BRUSH RELAY:M6 TORQUE TO 3.6-3.9Nm

RED 747631-1

X13

RED

X14

BLACK

INTERNAL INHIBIT RELAY

BLACK

RED

RED 747642

RED/VIO 747631-8

X12

BLACK

RED

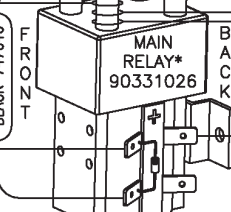

BLACK 747646

BLACK 747647

DIODE
740482

RED/VIO 747634-2

RED/VIO 747634-1

SPLIT CONDUIT
747627

SPLIT CONDUIT
747625

RED 747633-1

BLACK 747633-2

RED/VIO 747635-1

RED/VIO 747635-2

BLACK 747631-2

RED/VIO 747631-3

BLK/BLU 747631-6

BRUSH MOTOR RELAY*
747615

DIODE
740482

GRY/BLK 747655

RED 747638

BLACK 747639

GRN/YEL 747654

RED/BLK 747636

BLK/BLU 747631-7

RED/VIO 747631-3

BLK/BLU 747631-7

GRY/RED 747631-3

GRY/BLK 747657

GRY/RED 747656

X18

X17

OPTIONAL
HOUR METER
747624
K-E1720HM

GRY/BLK 747657

GRY/BLK 747656

WIRES ATTACHED TO
STUD IN ELECTRICAL
BOX



ACCESSORY CONNECTION
BLACK TAPED

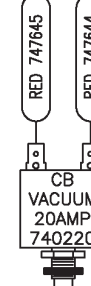
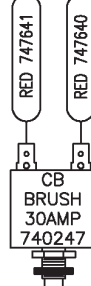
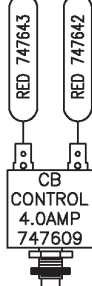

3

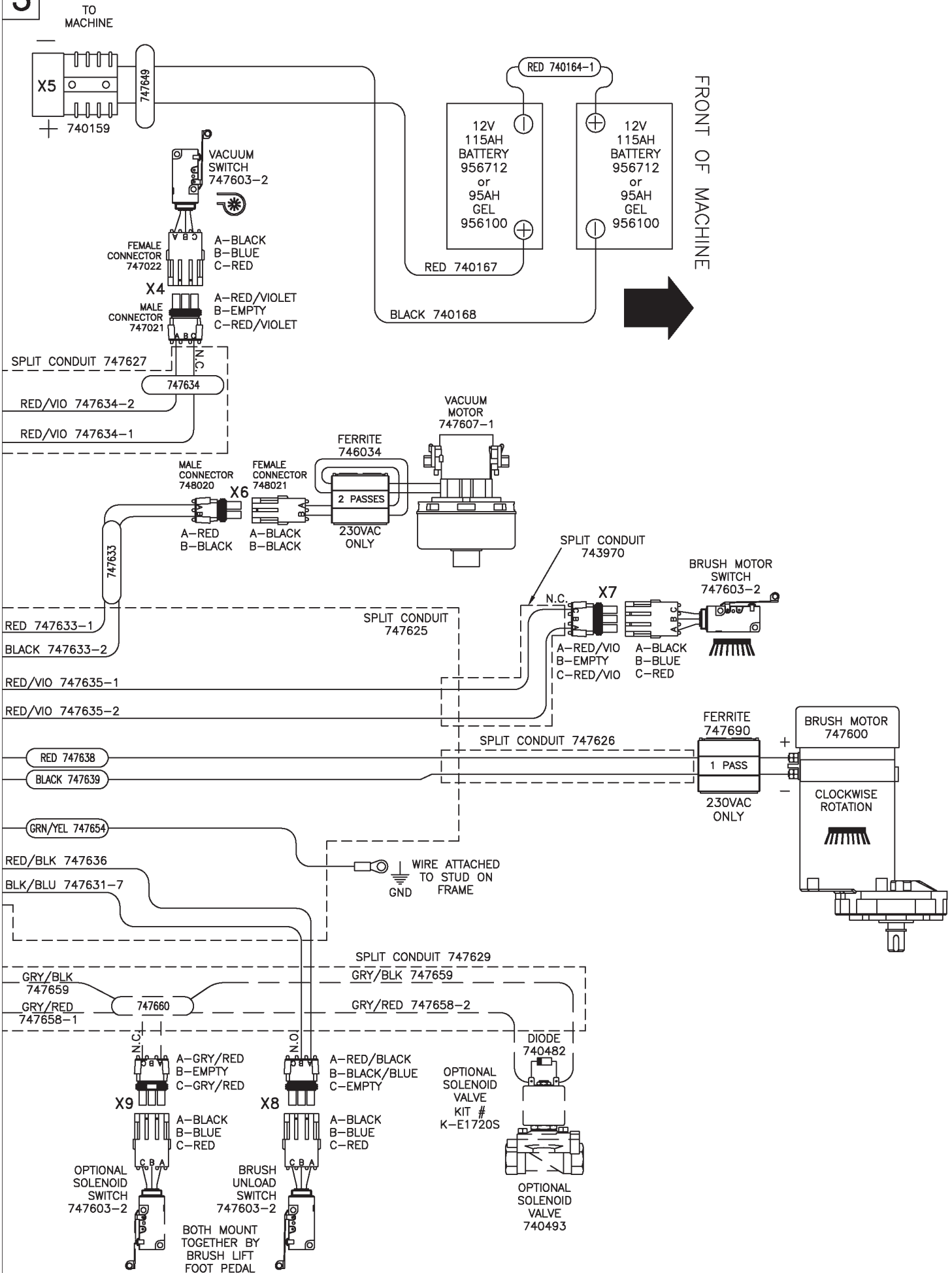

Minuteman International Made Simple Commercial Limited Warranty

Minuteman International, Inc. warrants to the original purchaser/user that the product is free from defects in workmanship and materials under normal use. Minuteman will, at its option, repair or replace without charge, parts that fail under normal use and service when operated and maintained in accordance with the applicable operation and instruction manuals. All warranty claims must be submitted through and approved by factory authorized repair stations.

This warranty does not apply to normal wear, or to items whose life is dependent on their use and care, such as belts, cords, switches, hoses, rubber parts, electrical motor components or adjustments. Parts manufactured by Minuteman are covered by and subject to the warranties and/or guarantees of their manufacturers. Please contact Minuteman for procedures in warranty claims against these manufacturers.

Special warning to purchaser -- Use of replacement filters and/or prefilters not manufactured by Minuteman or its designated licensees, will void all warranties expressed or implied. A potential health hazard exists without original equipment replacement.

All warranted items become the sole property of Minuteman or its original manufacturer, whichever the case may be.

Minuteman disclaims any implied warranty, including the warranty of merchantability and the warranty of fitness for a particular purpose. Minuteman assumes no responsibility for any special, incidental or consequential damages.

This limited warranty is applicable only in the U.S.A. and Canada, and is extended only to the original user/purchaser of this product. Customers outside the U.S.A. and Canada should contact their local distributor for export warranty policies. Minuteman is not responsible for costs or repairs performed by persons other than those specifically authorized by Minuteman. This warranty does not apply to damage from transportation, alterations by unauthorized persons, misuse or abuse of the equipment, use of non-compatible chemicals, or damage to property, or loss of income due to malfunctions of the product.

If a difficulty develops with this machine, you should contact the dealer from whom it was purchased.

This warranty gives you specific legal rights, and you may have other rights which vary from state to state. Some states do not allow the exclusion or limitation of special, incidental or consequential damages, or limitations on how long an implied warranty lasts, so the above exclusions and limitations may not apply to you.

Cord Electric Group... .. Three years parts, two years labor, ninety days travel (Not to exceed two hours)

Exceptions... .. Port-A-Scrub, one year parts, six months labor
MPV 13, one year parts
V-14, one year parts, one year labor
MPV 14 and 18, two years parts, one year labor
RapidAir blower, one year parts, one year labor
Explosion-Proof Vacuum, one year parts, one year labor
X12 and X12H, one year parts, one year labor
TRS 14, one year parts, one year labor

Battery Operated Group... .. Three years parts, two years labor, ninety days travel
(Not to exceed two hours)

Exceptions... .. Sweepers, one year parts, one year labor, ninety days travel
(Not to exceed two hours)

Internal Combustion Group... .. One year parts, one year labor, ninety day travel
(Not to exceed two hours)

Battery Chargers... .. One year replacement

Replacement Parts... .. Ninety days

Batteries... .. 0-3 months replacement, 4-12 months pro-rate

Polypropylene Plastic Tanks... .. Ten years, no additional labor